

THIS DWG. IS SOLE PROPERTY OF PASKALS FLUID SYSTEM PVT. LTD. UNAUTHORISED USE OF THIS DWG. OR MAKING PRODUCT AS PER THIS DWG. WITHOUT OUR PERMISSION OR ANY OTHER MISUSE IS NOT PERMITTED.

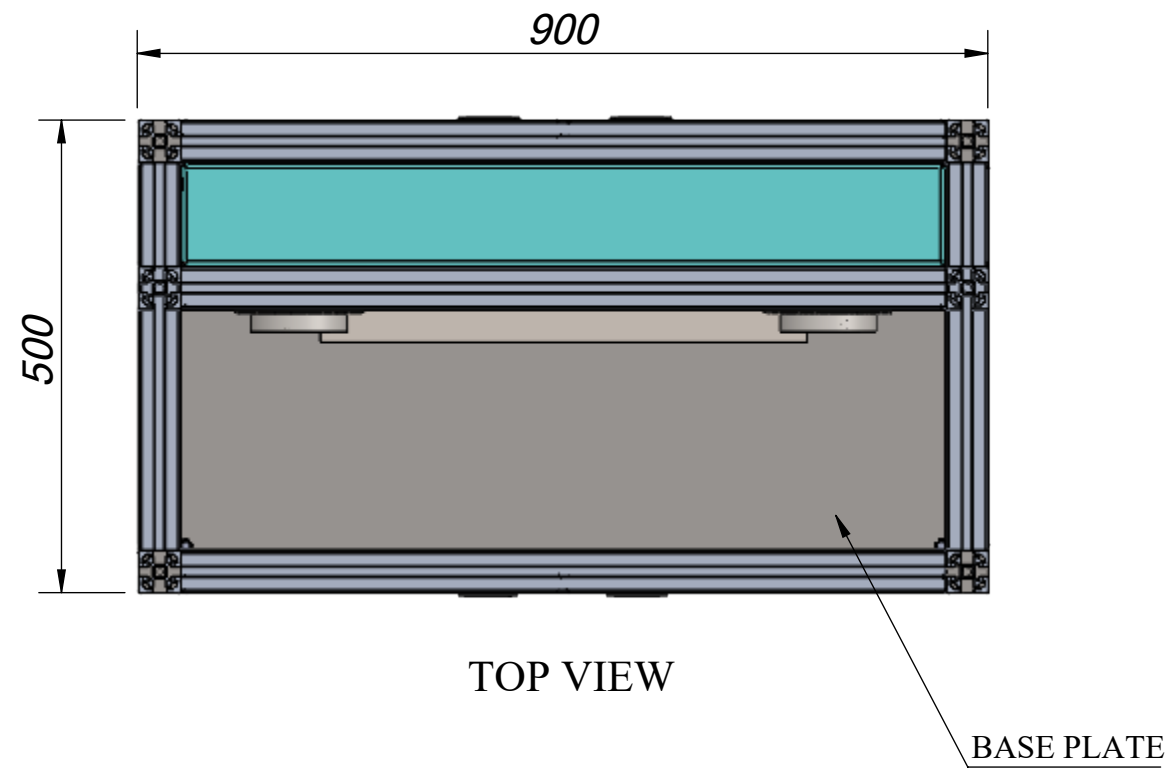

TOP VIEW

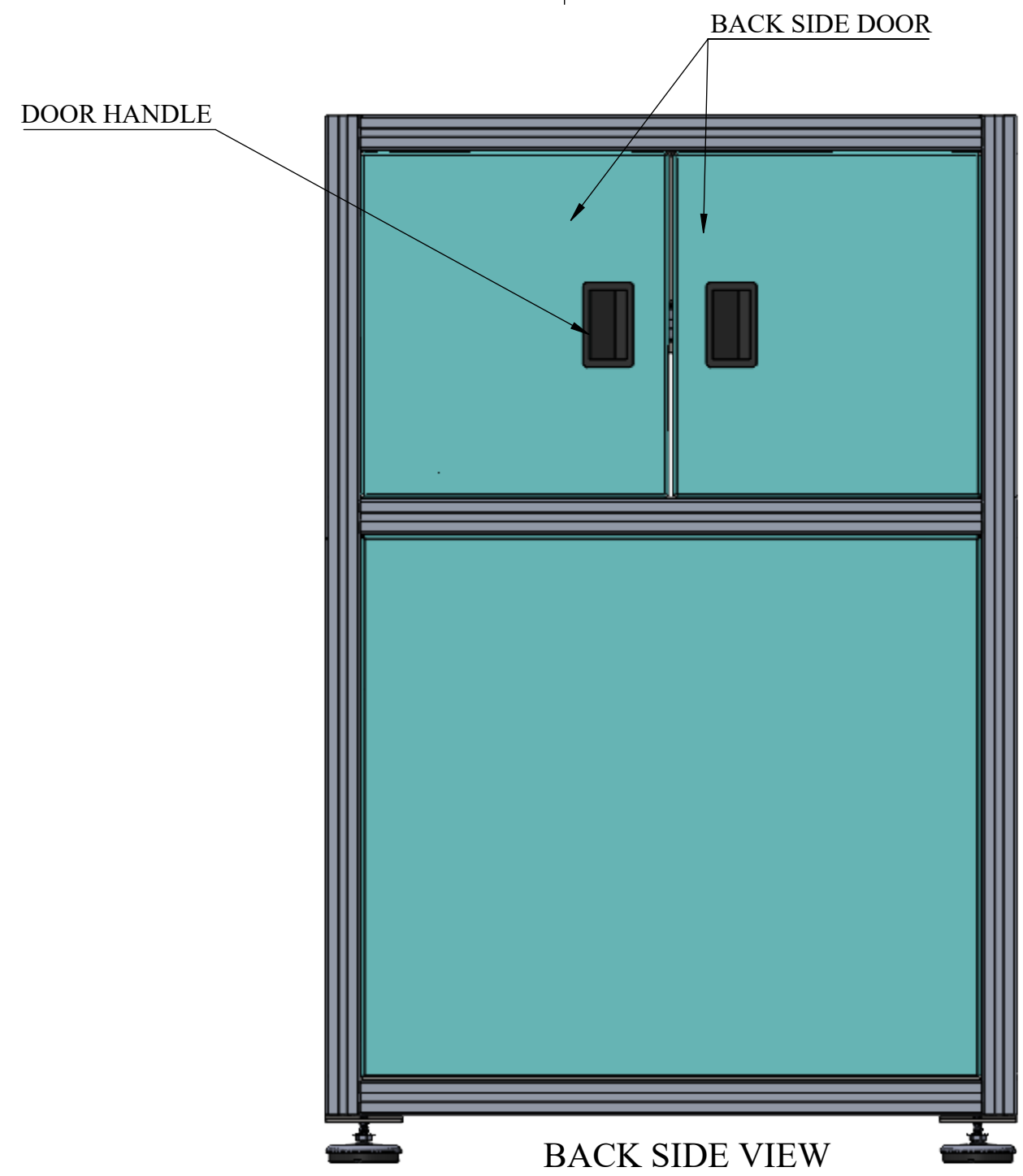

BACK SIDE VIEW

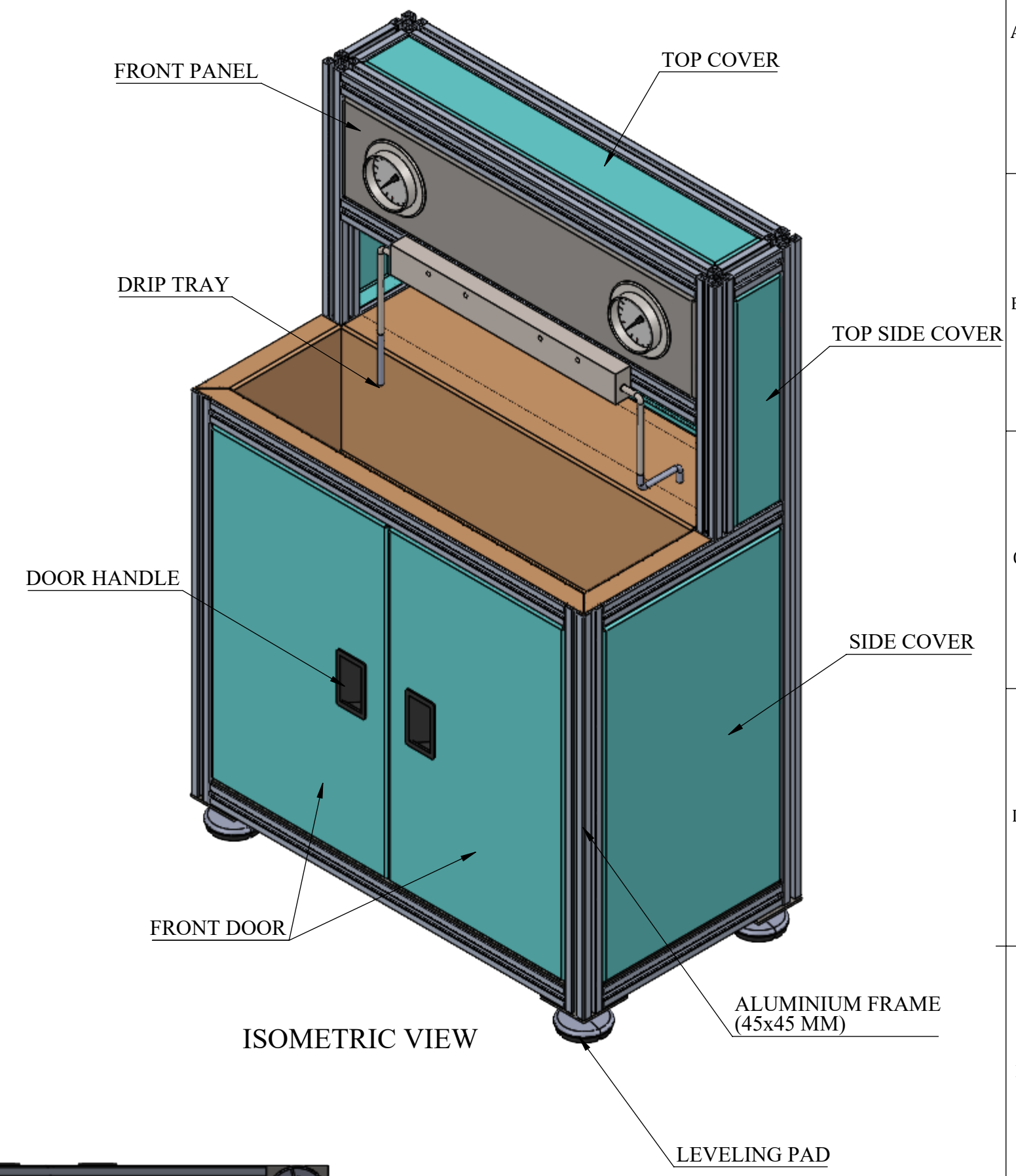

ISOMETRIC VIEW

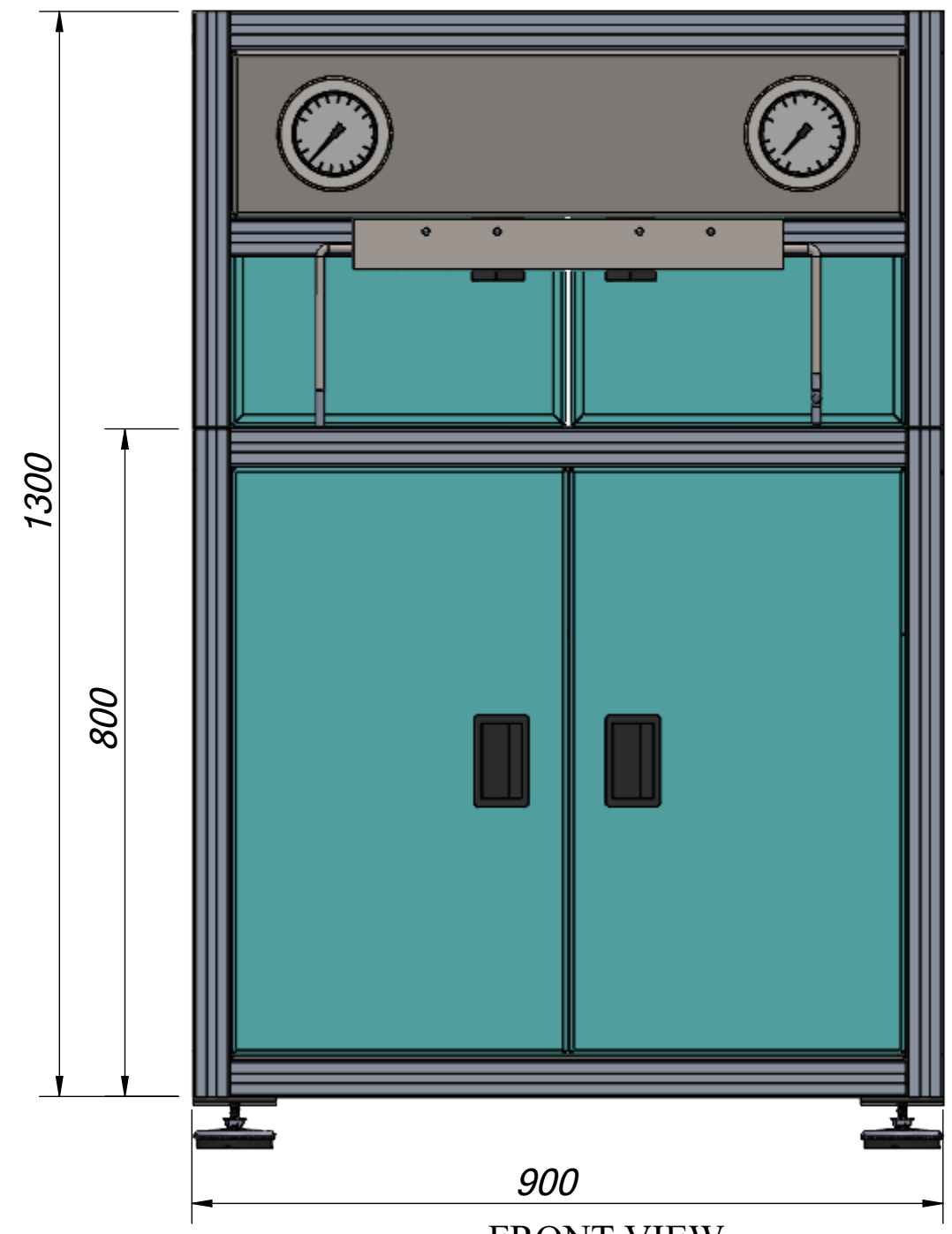

FRONT VIEW

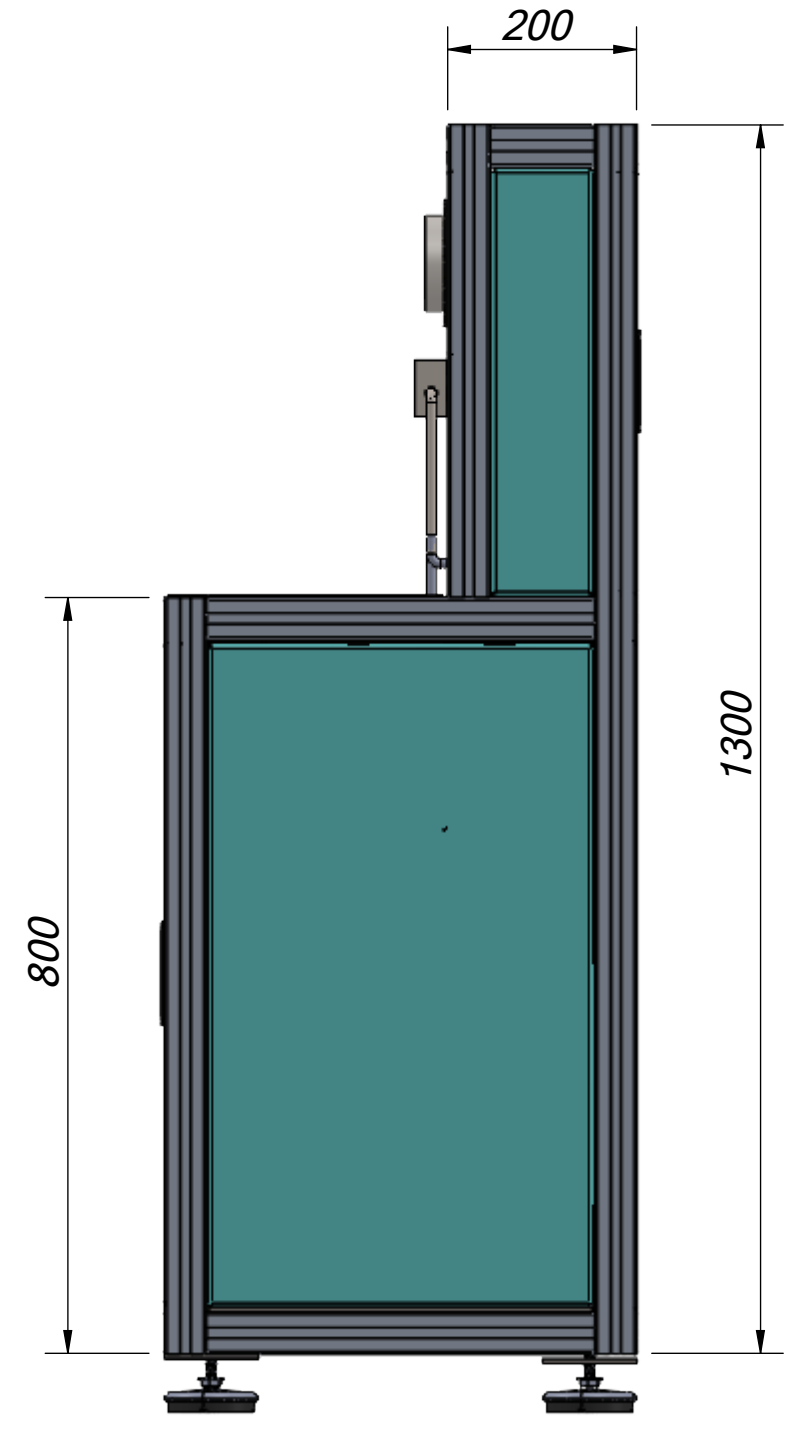

SIDE VIEW

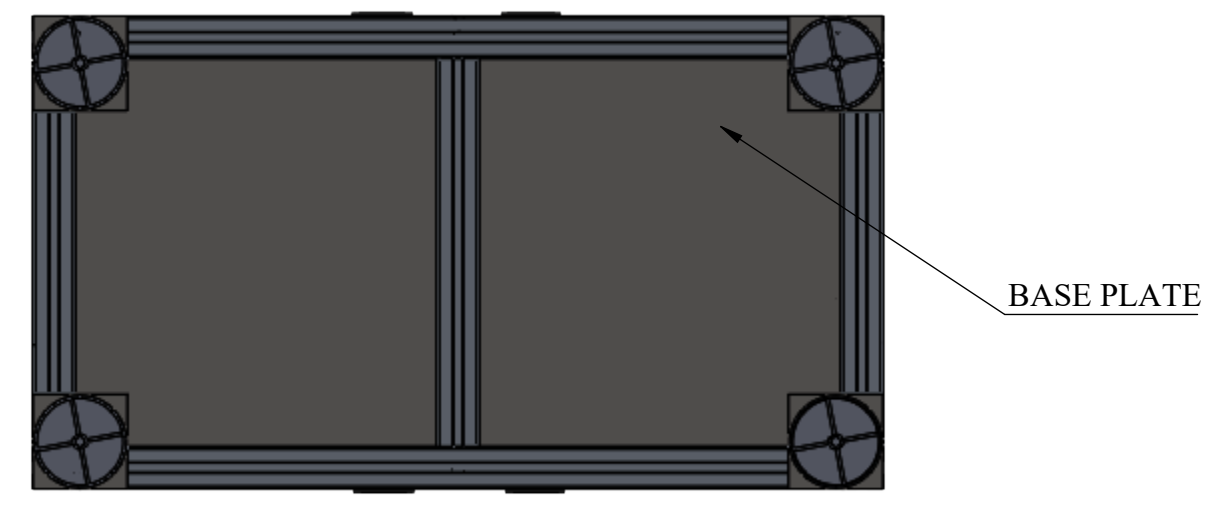

BOTTOM VIEW

NOTE:-
1. ALL DIMENSIONS ARE IN MM.

PASKALS Fluid Systems		PASKALS FLUID SYSTEM PVT LTD. E-148, SECTOR 63, NOIDA, UP-201301 Tel No.: 0120 4500800 Fax No.: 0120 4500888 E-mail: bd@paskals.com			
TITLE	NOZZLE TESTING SYSTEM			QA No.	
SUB-TITLE	GA DRAWING			Cross Ref Doc No.:	
SRS CODE	P3426			Customer Dwg Ref No.	
CUSTOMER	--			NOTE:	
END USER	--				
TD/PO. No.	--			DATED	
PROJECTION	DRWN	M.F	16/11/2024	SIZE	SCALE
	CHK.	P.N	16/11/2024	A3	NTS
	APPR.	S.P.S	16/11/2024	SHEET	No OF
				01	01
				NEO DWG No.	REV
				T-DAP-P426-GADWG-NTS	00

THIS DWG. IS SOLE PROPERTY OF PASKALS FLUID SYSTEM PVT. LTD.
 UNAUTHORISED USE OF THIS DWG. OR MAKING PRODUCT AS PER THIS
 DWG. WITHOUT OUR PERMISSION OR ANY OTHER MISUSE IS NOT
 PERMITTED.

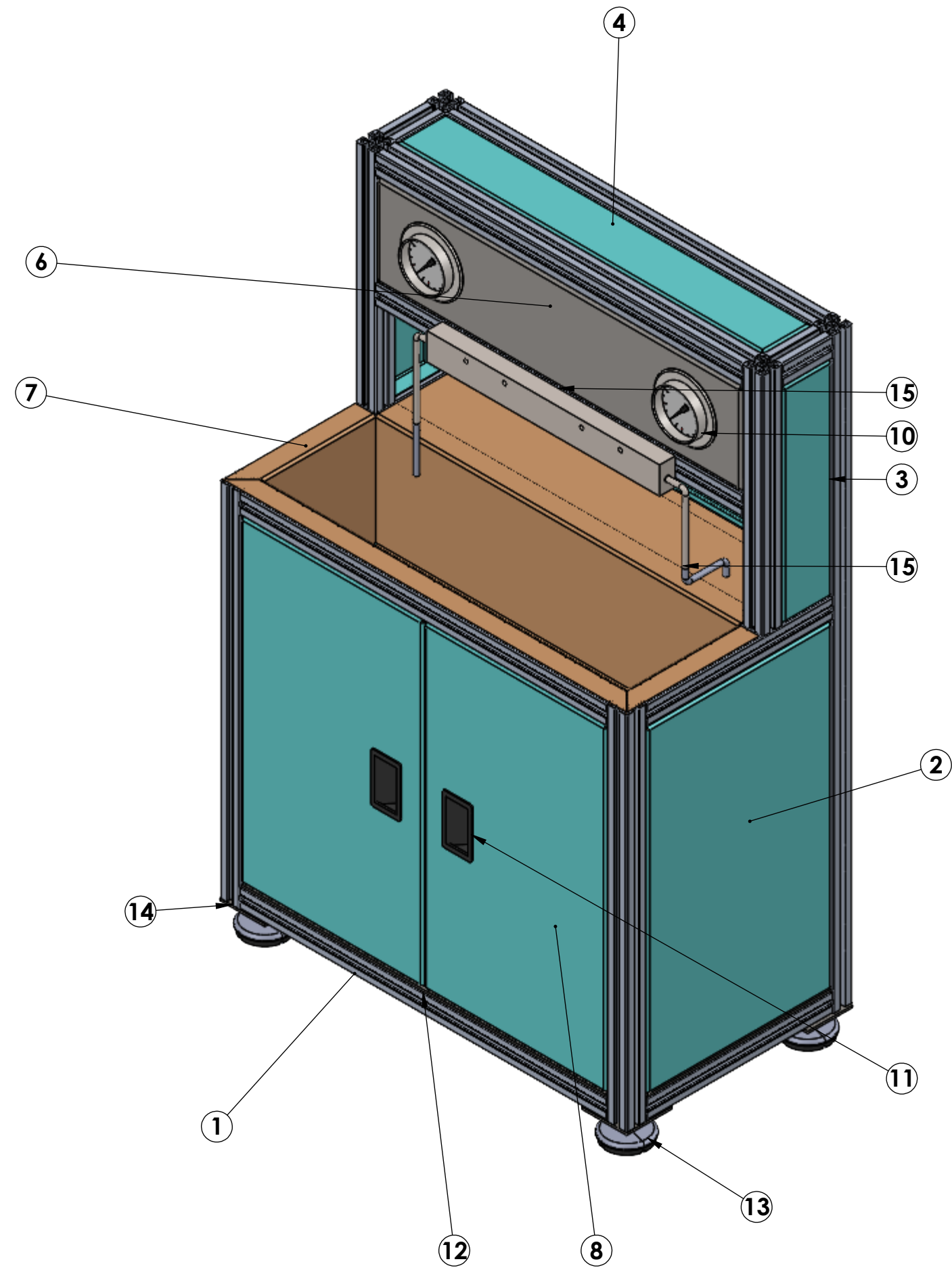

ITEM NO.	PART NUMBER	QTY.
1	FRAME ASSEMBLY	1
2	SIDE COVER	2
3	TOP SIDE COVER	2
4	TOP COVER	1
5	BACK COVER	1
6	FRONT PANEL	1
7	DRIP TRAY	1
8	FRONT DOOR-1	2
9	BACK DOOR-2	2
10	PRESSURE GAUGE 4INCH	2
11	DOOR LOCK	4
12	BASE PLATE	1
13	LEVELING PAD	4
14	LEVELING PAD PLATE	4
15	MANIFOLD	1

		PASKALS FLUID SYSTEM PVT LTD. E-148, SECTOR 63, NOIDA, UP-201301 Tel No.: 0120 4500880 Fax No.: 0120 4500888 E-mail: bd@paskals.com	
		QA No.	
TITLE	NOZZLE TESTING SYSTEM		Cross Ref Doc No.:
SUB-TITLE	GA DRAWING		
SRS CODE	P3426		Customer Dwg Ref No.
CUSTOMER	--		NOTE :
END USER	--		
TD/PO. No.	--		
PROJECTION		DRWN	M.F
		CHK.	P.N
		APPR.	S.P.S
		16/11/2024	16/11/2024
SIZE	SCALE	SHEET No	OF
A3	NTS	01	01
NEO DWG No.		REV	
T-DAP-P426-GADWG-NTS		00	

THIS DWG. IS SOLE PROPERTY OF PASKALS FLUID SYSTEM PVT. LTD. UNAUTHORISED USE OF THIS DWG. OR MAKING PRODUCT AS PER THIS DWG. WITHOUT OUR PERMISSION OR ANY OTHER MISUSE IS NOT PERMITTED.

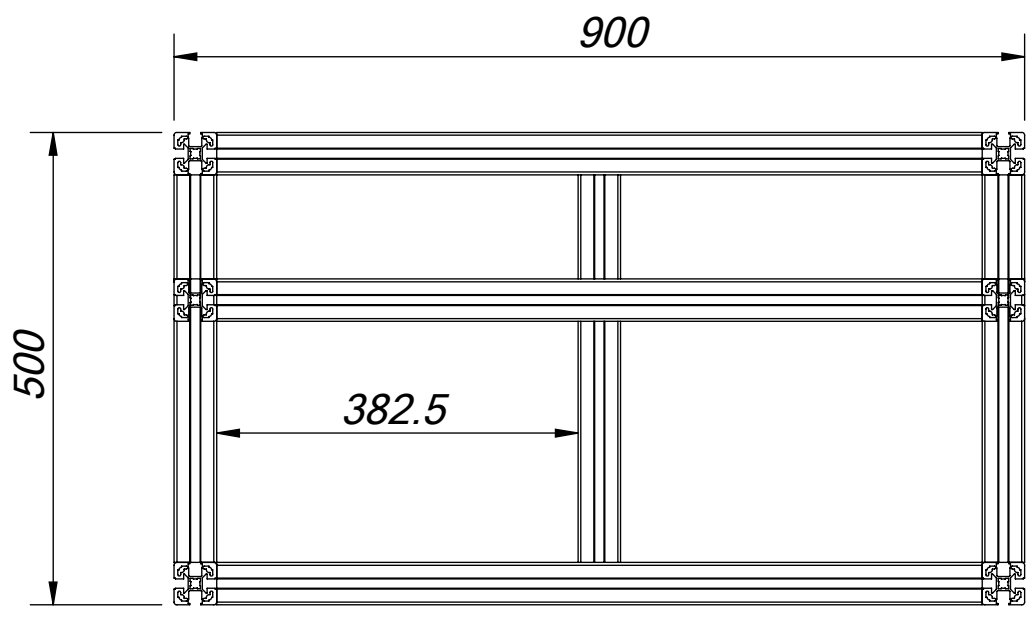

TOP VIEW

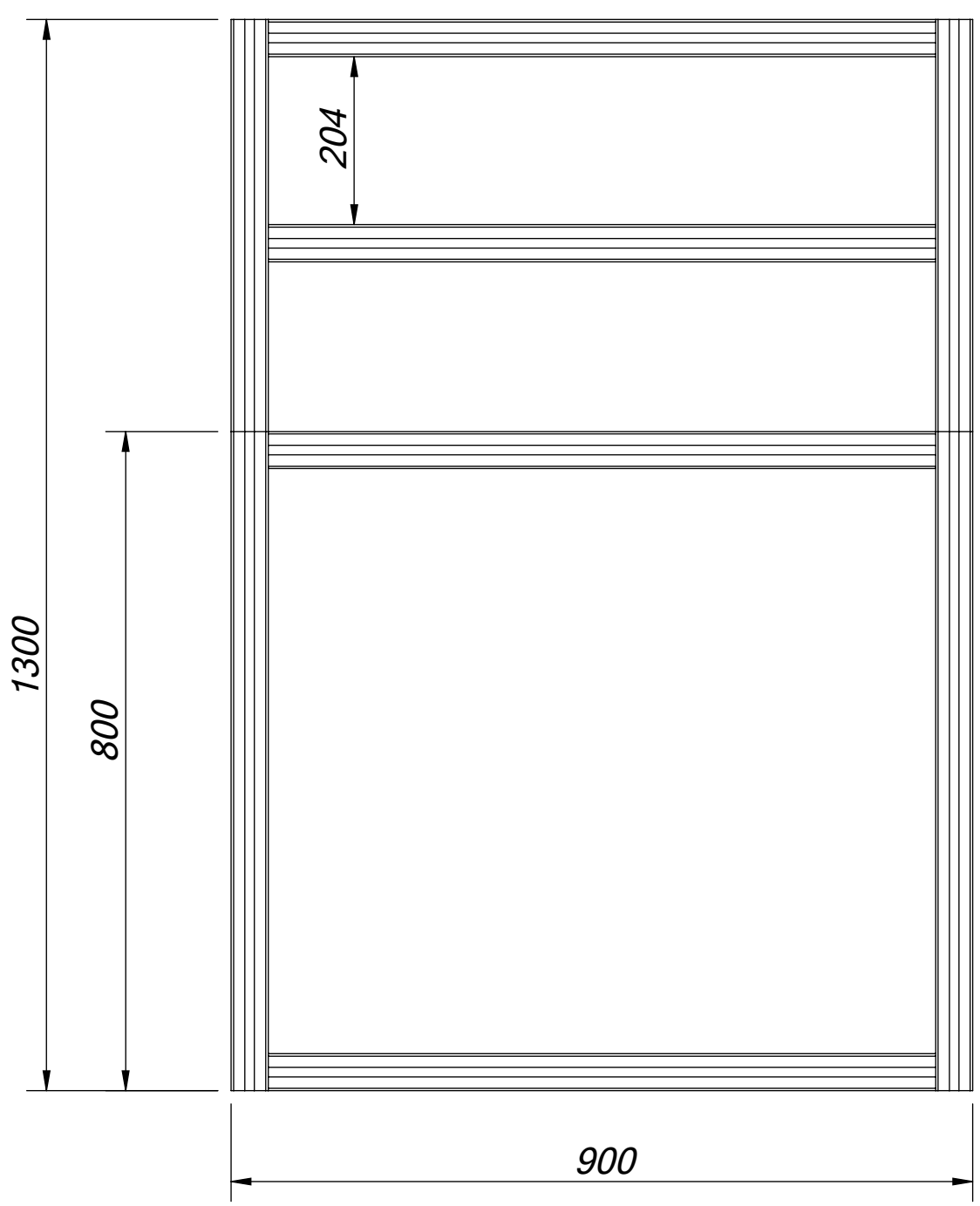

FRONT VIEW

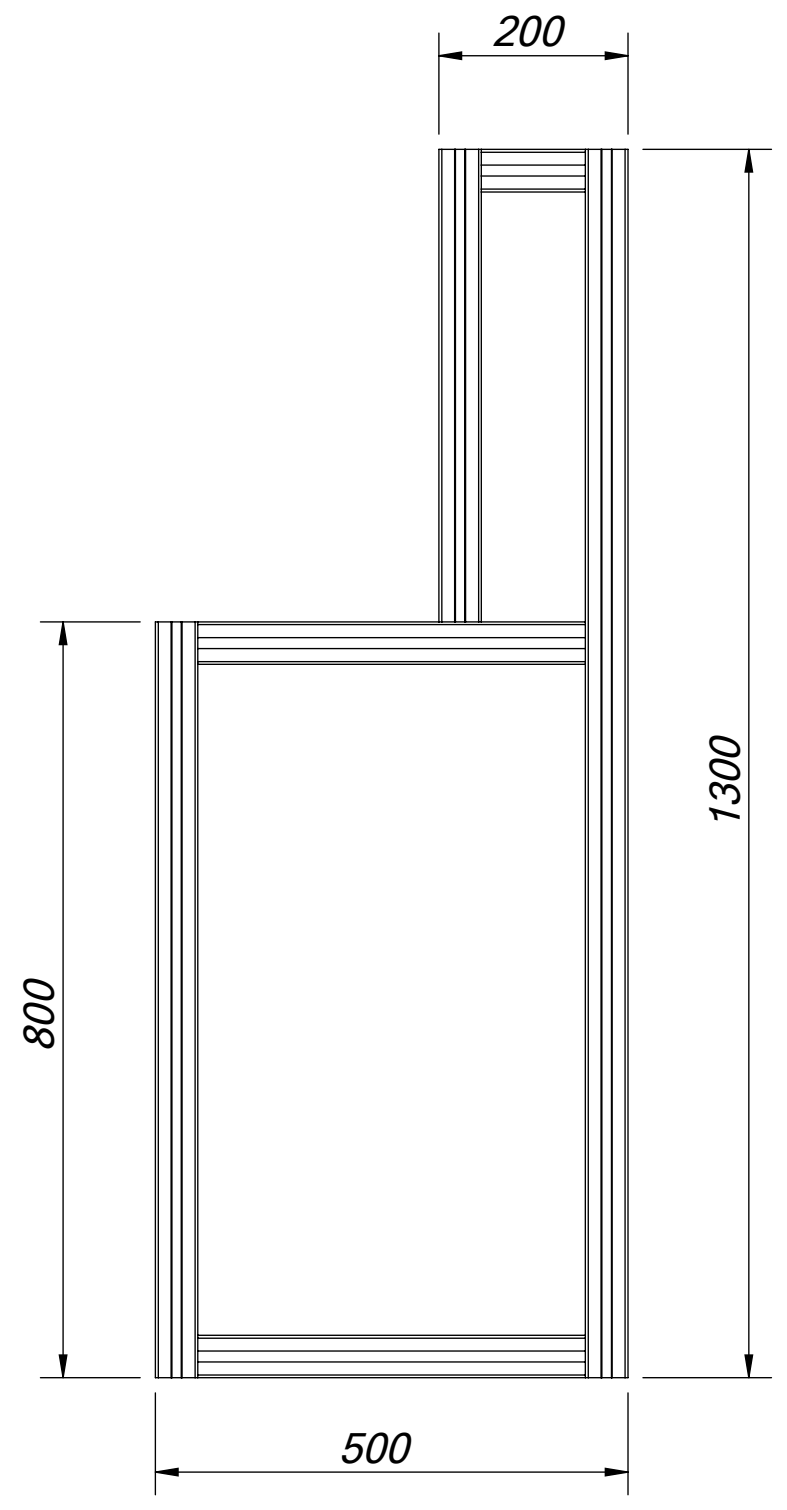

SIDE VIEW

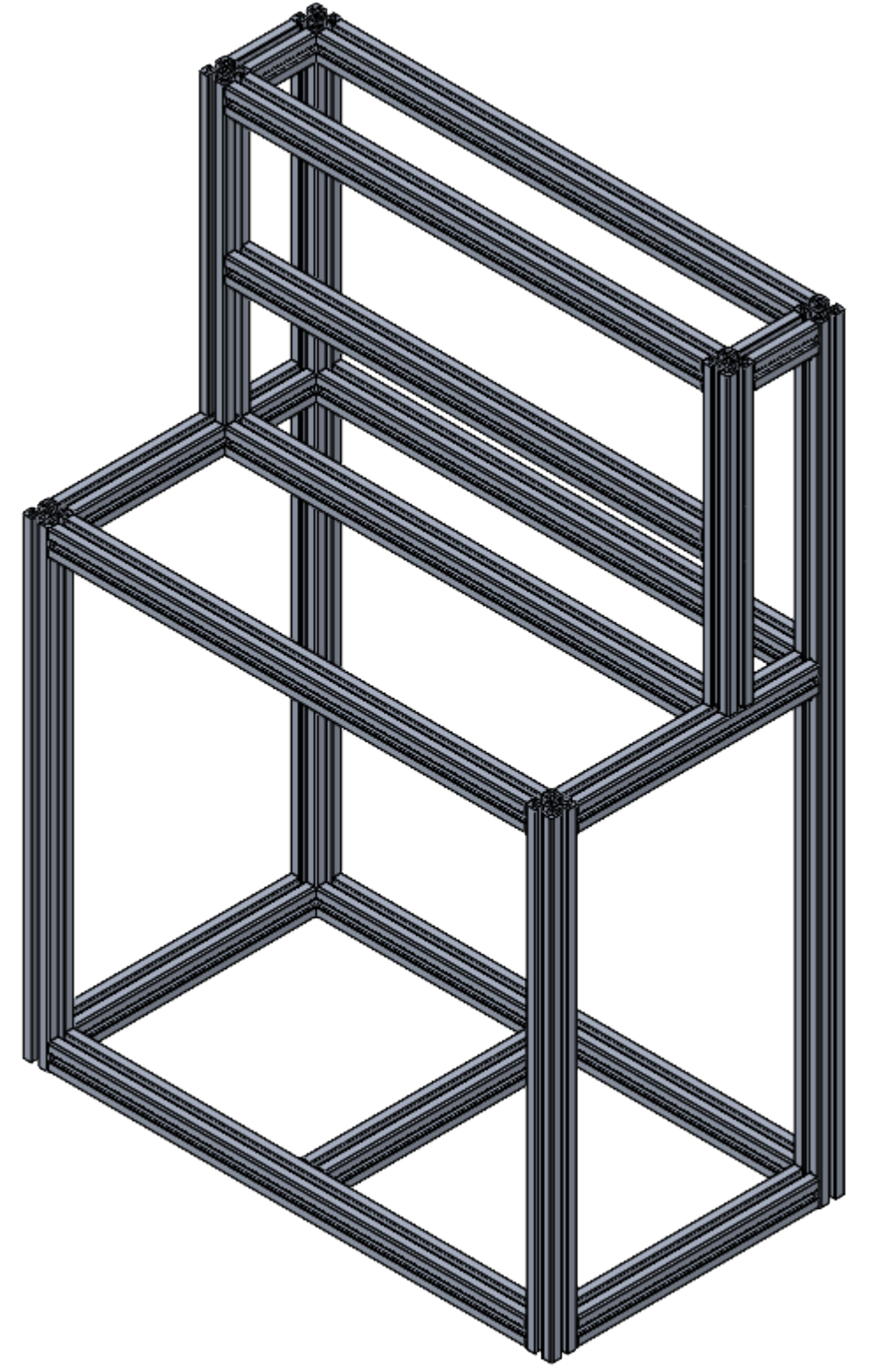

ISOMETRIC VIEW

NOTE:-

1. ALL DIMENSIONS ARE IN MM.
2. MATERIAL- ALUMINIUM
3. QTY.- 1 NOS
4. USED AL. PROFILE- 45x45 MM

FRAME

PASKALS Fluid Systems		PASKALS FLUID SYSTEM PVT LTD. E-148, SECTOR 63, NOIDA, UP-201301 Tel No.: 0120 4500800 Fax No.: 0120 4500888 E-mail: bd@paskals.com			
TITLE	NOZZLE TEST SYSTEM			QA No.	
SUB-TITLE	FRAME			Cross Ref Doc No.:	
SRS CODE	P3426			Customer Dwg Ref No.	
CUSTOMER	--			NOTE :	
END USER	--				
TD/PO. No.	--			DATED	
PROJECTION	DRWN	M.F	16/11/2024	SIZE	SCALE
	CHK.	P.N	16/11/2024	A3	NTS
	APPR.	S.P.S	16/11/2024	SHEET No. 01	OF 01
				NEO DWG No.	REV
				T-PED-P3426-MDWG-FRAME	00

THIS DWG. IS SOLE PROPERTY OF PASKALS FLUID SYSTEM PVT. LTD. UNAUTHORISED USE OF THIS DWG. OR MAKING PRODUCT AS PER THIS DWG. WITHOUT OUR PERMISSION OR ANY OTHER MISUSE IS NOT PERMITTED.

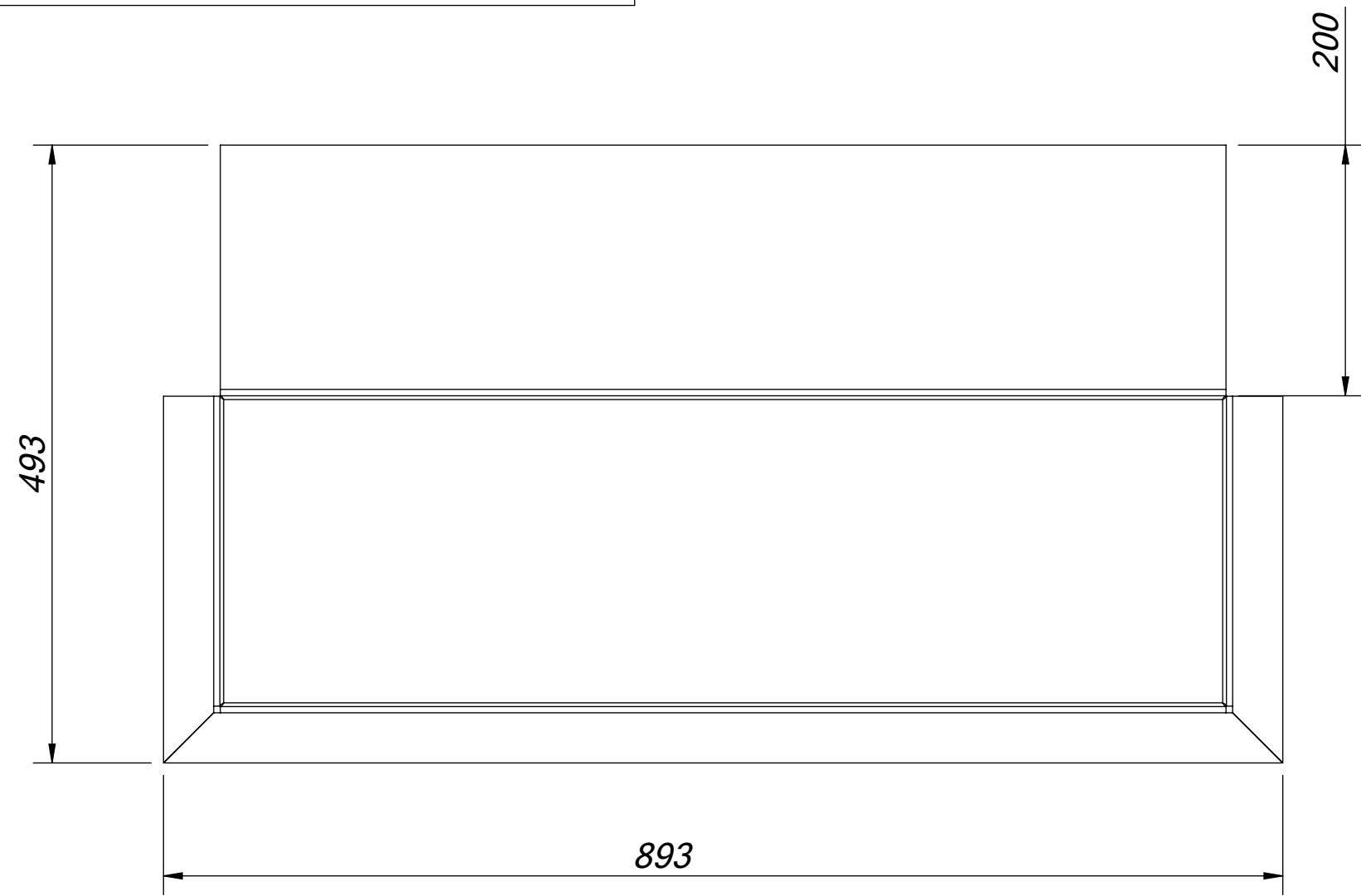

TOP VIEW

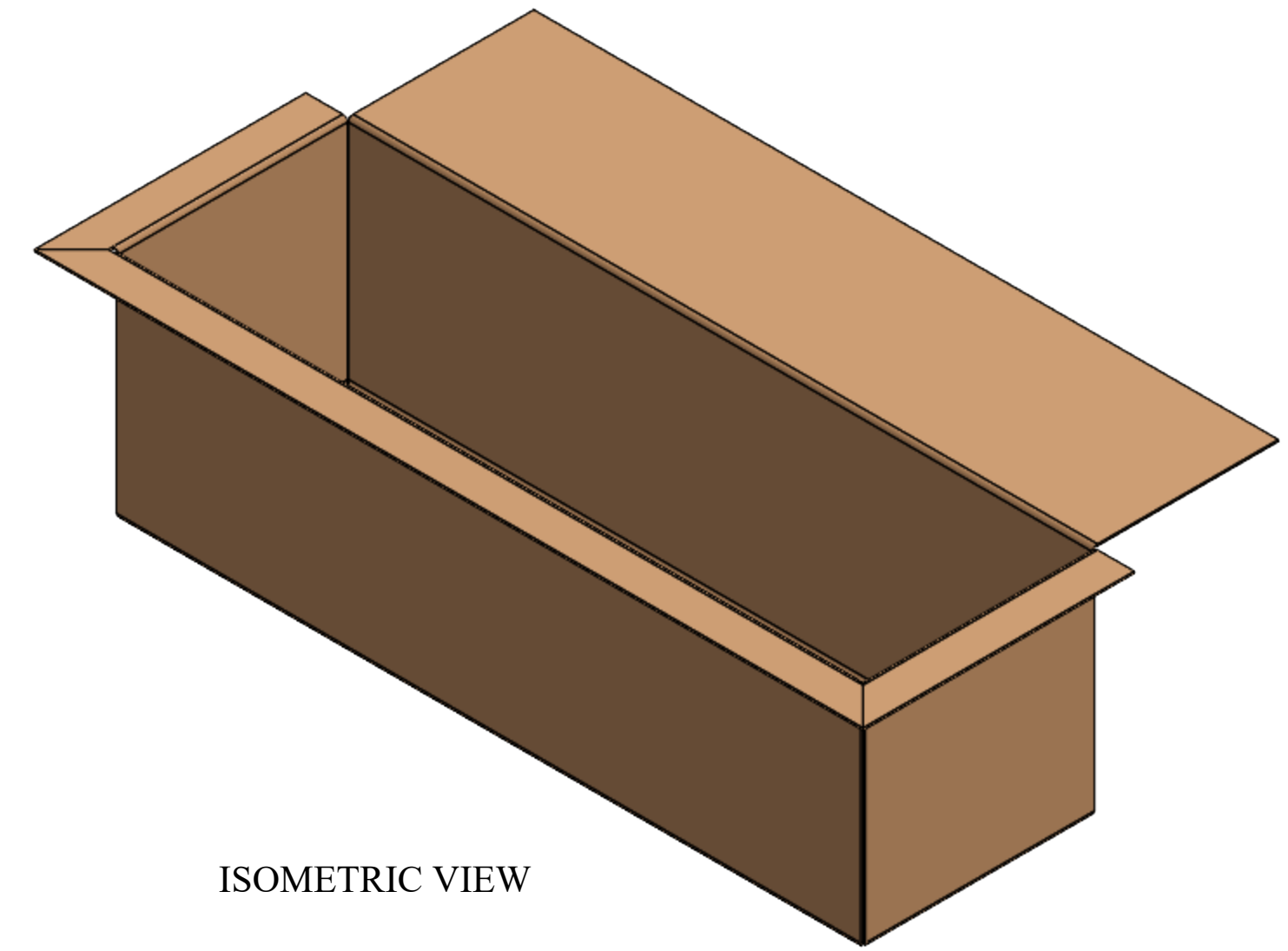

ISOMETRIC VIEW

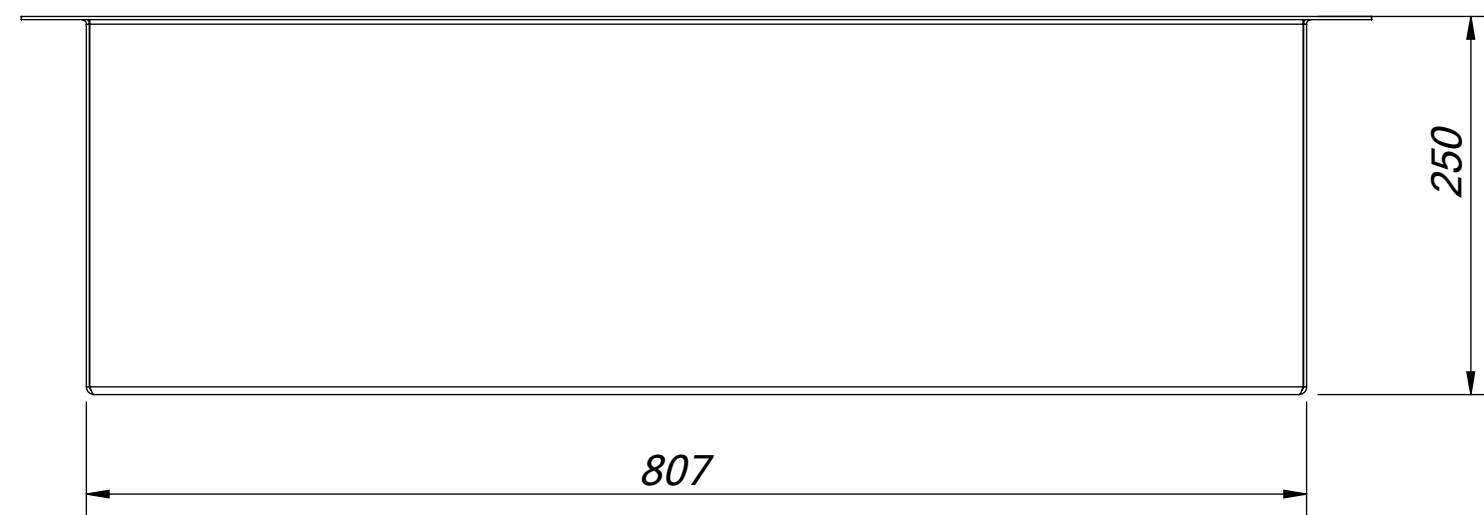

FRONT VIEW

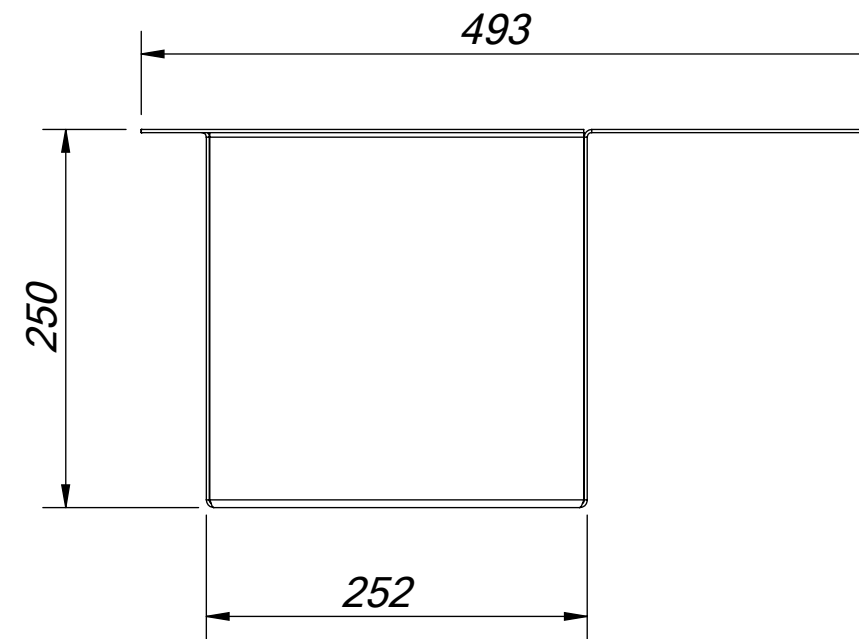

SIDE VIEW

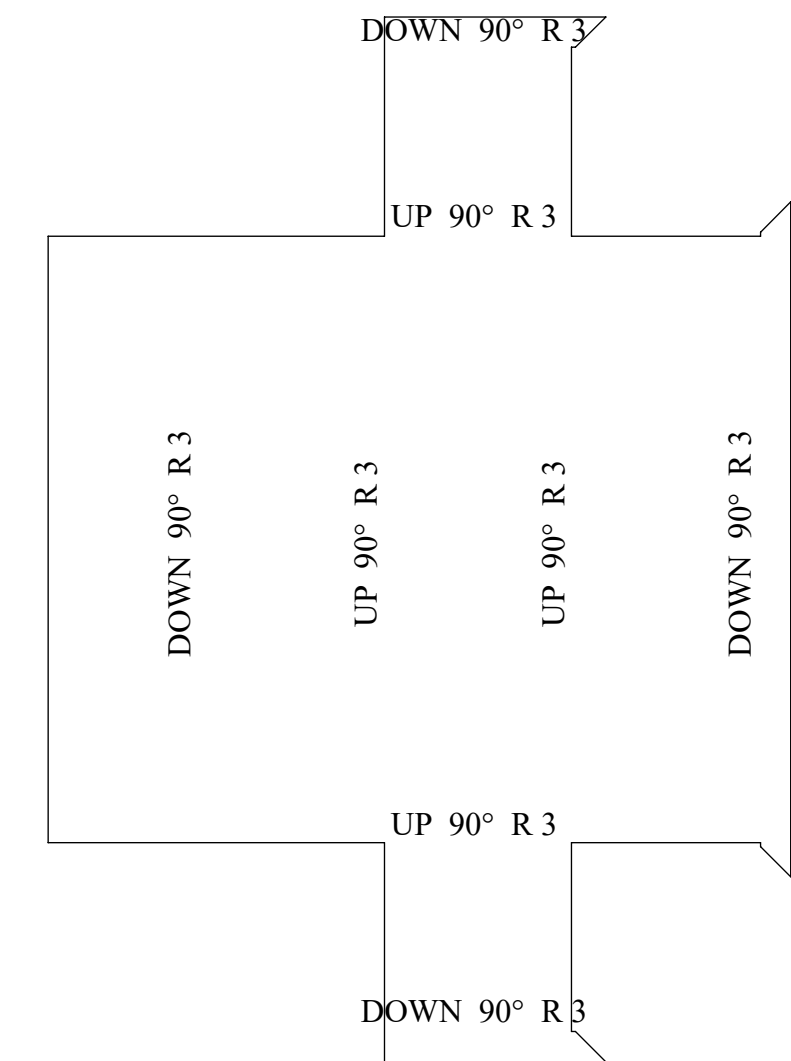

Flat pattern

DRIP TRAY

NOTE:-

1. ALL DIMENSIONS ARE IN MM.
2. MATERIAL- SS
3. SHEET THK.- 2 MM
4. QTY.- 1 NOS.
5. FINISH WEIGHT- 13 KG.

PASKALS Fluid Systems		PASKALS FLUID SYSTEM PVT LTD. E-148, SECTOR 63, NOIDA, UP-201301 Tel No.: 0120 4500800 Fax No.: 0120 4500888 E-mail: bd@paskals.com			
TITLE	NOZZLE TEST SYSTEM			QA No.	
SUB-TITLE	DRIP TRAY			Cross Ref Doc No.:	
SRS CODE	P3426			Customer Dwg Ref No.	
CUSTOMER	--			NOTE :	
END USER	--				
TD/PO. No.	--			DATED	
PROJECTION	DRWN	M.F	16/11/2024	SIZE	SCALE
	CHK.	P.N	16/11/2024	A3	NTS
	APPR.	S.P.S	16/11/2024		
				SHEET No	OF
				01	01
				NEO DWG No.	REV
				T-PED-P3426-MDWG-DRIP TRAY	00

THIS DWG. IS SOLE PROPERTY OF PASKALS FLUID SYSTEMS PVT. LTD.
 UNAUTHORISED USE OF THIS DWG. OR MAKING PRODUCT AS PER THIS
 DWG. WITHOUT OUR PERMISSION OR ANY OTHER MISUSE IS NOT PERMITTED.

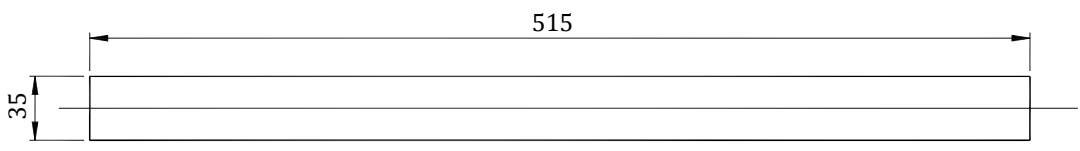

TOP VIEW

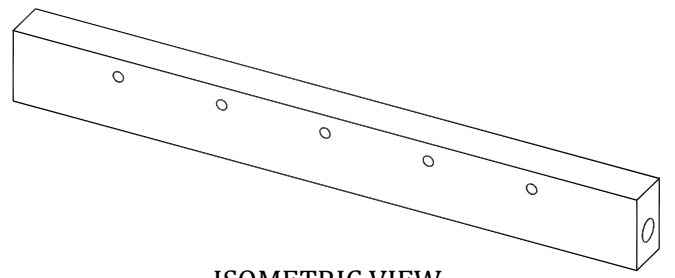

ISOMETRIC VIEW

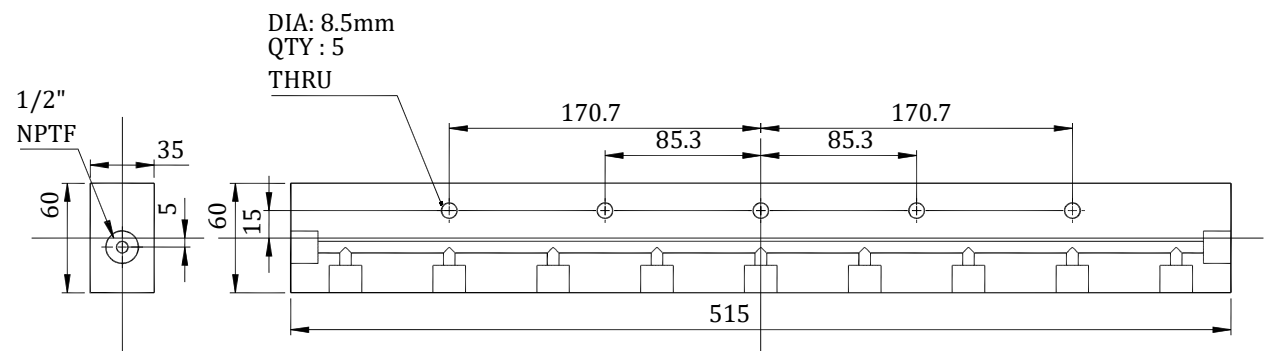

LEFT SIDE VIEW

FRONT VIEW

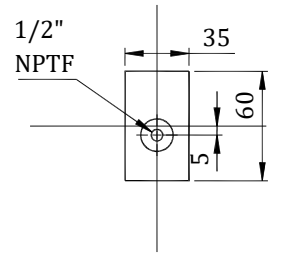

RIGHT SIDE VIEW

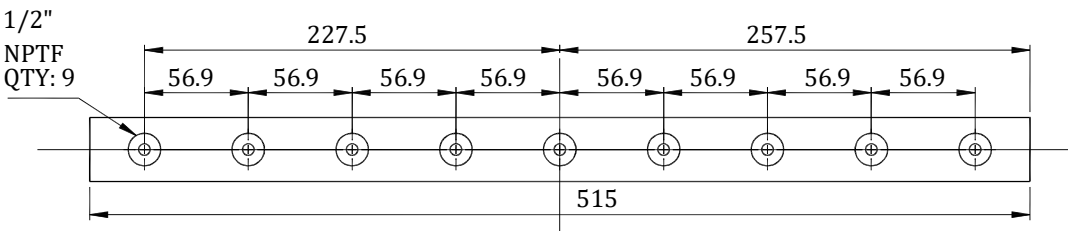

BOTTOM VIEW

- Note :
- All dimensions are in mm.
 - Material : S.S. 304
 - Remove all rough edges and burrs.

PASKALS Advanced Fluid Systems		PASKALS FLUID SYSTEMS PRIVATE LIMITED E-148, SECTOR-63, NOIDA-201301 (U.P.) Tel. Phone No.- 0120-4500800, E-Mail: Contact@neometrix.in	
Main-Title	NOZZLE TESTING MACHINE	O.A No.	
Sub-Title	MANIFOLD	Cross Ref. Doc.	
Code	P3426	Customer Dwg. & Ref No.	
Customer	-----	Note.	
End User	-----		
Application	-----		
Projection	Drawn By & Date	M.S. 25/11/24	Sheet
	Checked By & Date	P.M. 25/11/24	Scale
	Approved By & Date	S.P.S. 25/11/24	Sheet No. Of
			01 01
			Paskals Dwg No. REV.
			T-PED-P3426-MDWG-MF 00

THIS DWG. IS SOLE PROPERTY OF PASKALS FLUID SYSTEM PVT. LTD.
 UNAUTHORISED USE OF THIS DWG. OR MAKING PRODUCT AS PER THIS
 DWG. WITHOUT OUR PERMISSION OR ANY OTHER MISUSE IS NOT
 PERMITTED.

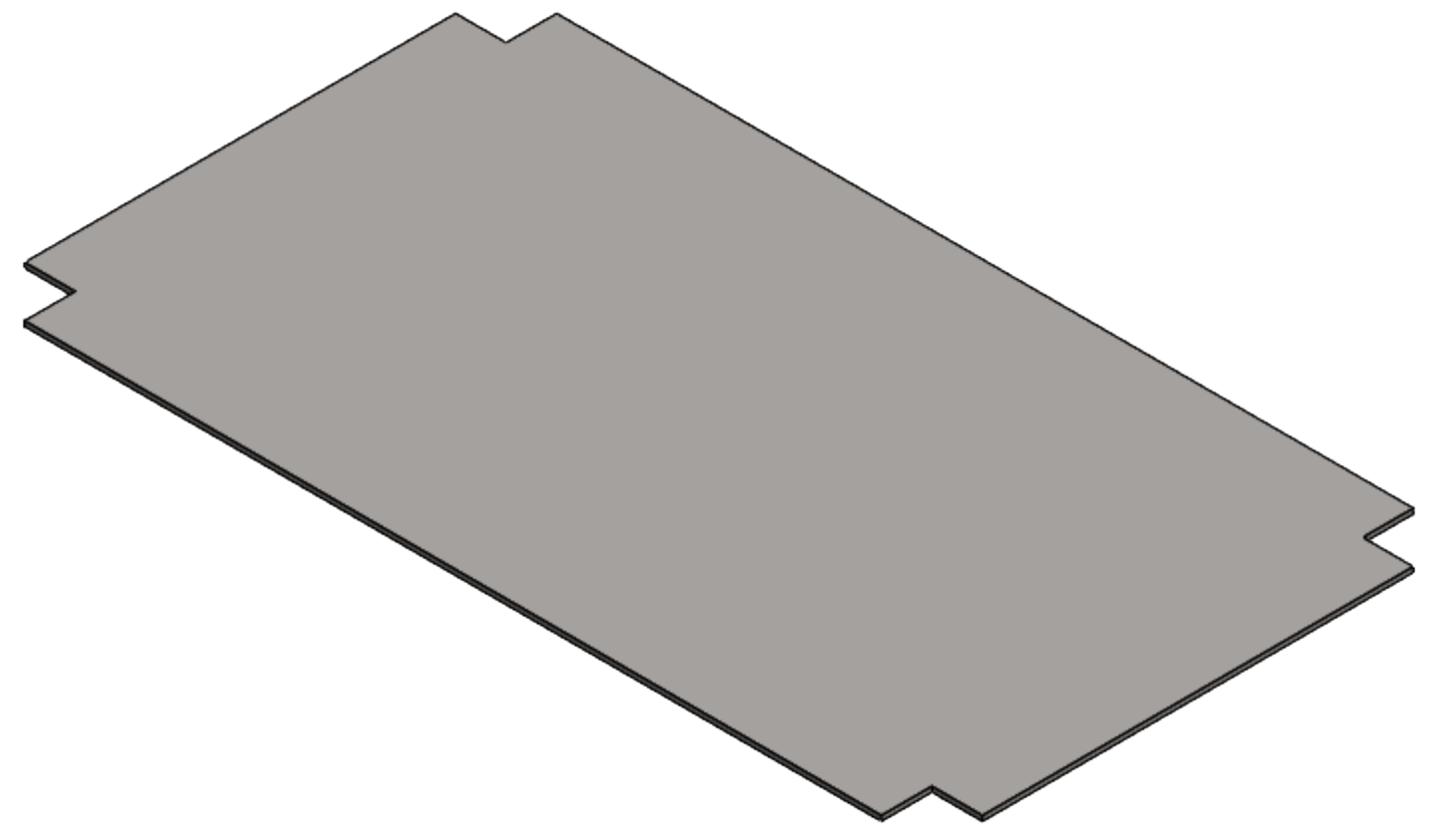
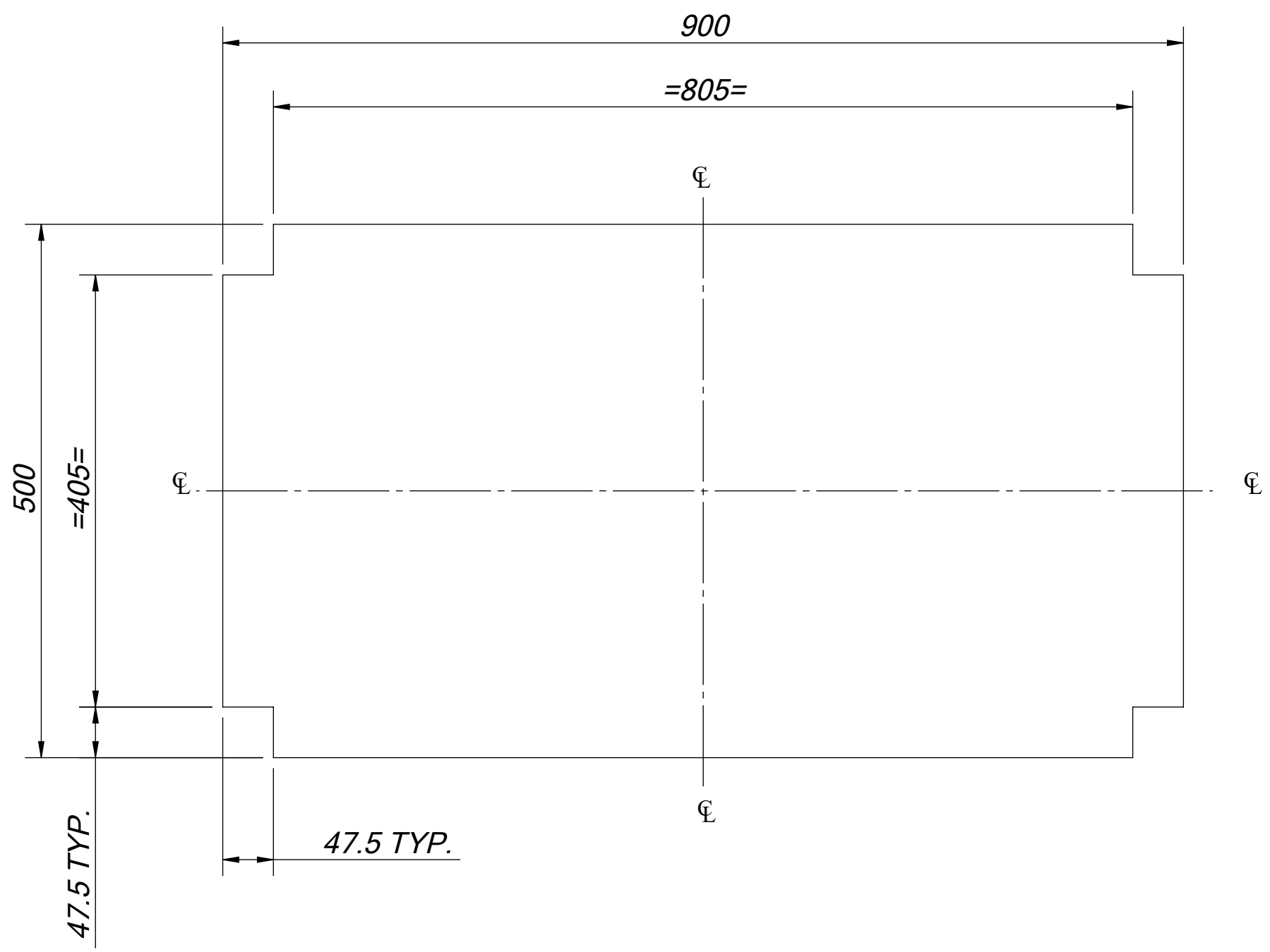

BASE PLATE

NOTE:-

1. ALL DIMENSIONS ARE IN MM.
2. MATERIAL- MS
3. SHEET THK.- 5 MM
4. QTY.- 1 NOS.
5. FINISH WEIGHT- 17 KG.

PASKALS Fluid Systems		PASKALS FLUID SYSTEM PVT LTD. E-148, SECTOR 63, NOIDA, UP-201301 Tel No.: 0120 4500880 Fax No.: 0120 4500888 E-mail: bd@paskals.com			
TITLE	NOZZLE TEST SYSTEM			QA No.	
SUB-TITLE	BASE PLATE			Cross Ref Doc No.:	
SRS CODE	P3426			Customer Dwg Ref No.	
CUSTOMER	--			NOTE :	
END USER	--				
TD/PO. No.	--			DATED	
PROJECTION	DRWN	M.F	16/11/2024	SIZE	SCALE
	CHK.	P.N	16/11/2024	A3	NTS
	APPR.	S.P.S	16/11/2024		
				SHEET No	01
				OF	01
				NEO DWG No.	
				T-PED-P3426-MDWG-BASE PLATE	00

THIS DWG. IS SOLE PROPERTY OF PASKALS FLUID SYSTEM PVT. LTD. UNAUTHORISED USE OF THIS DWG. OR MAKING PRODUCT AS PER THIS DWG. WITHOUT OUR PERMISSION OR ANY OTHER MISUSE IS NOT PERMITTED.

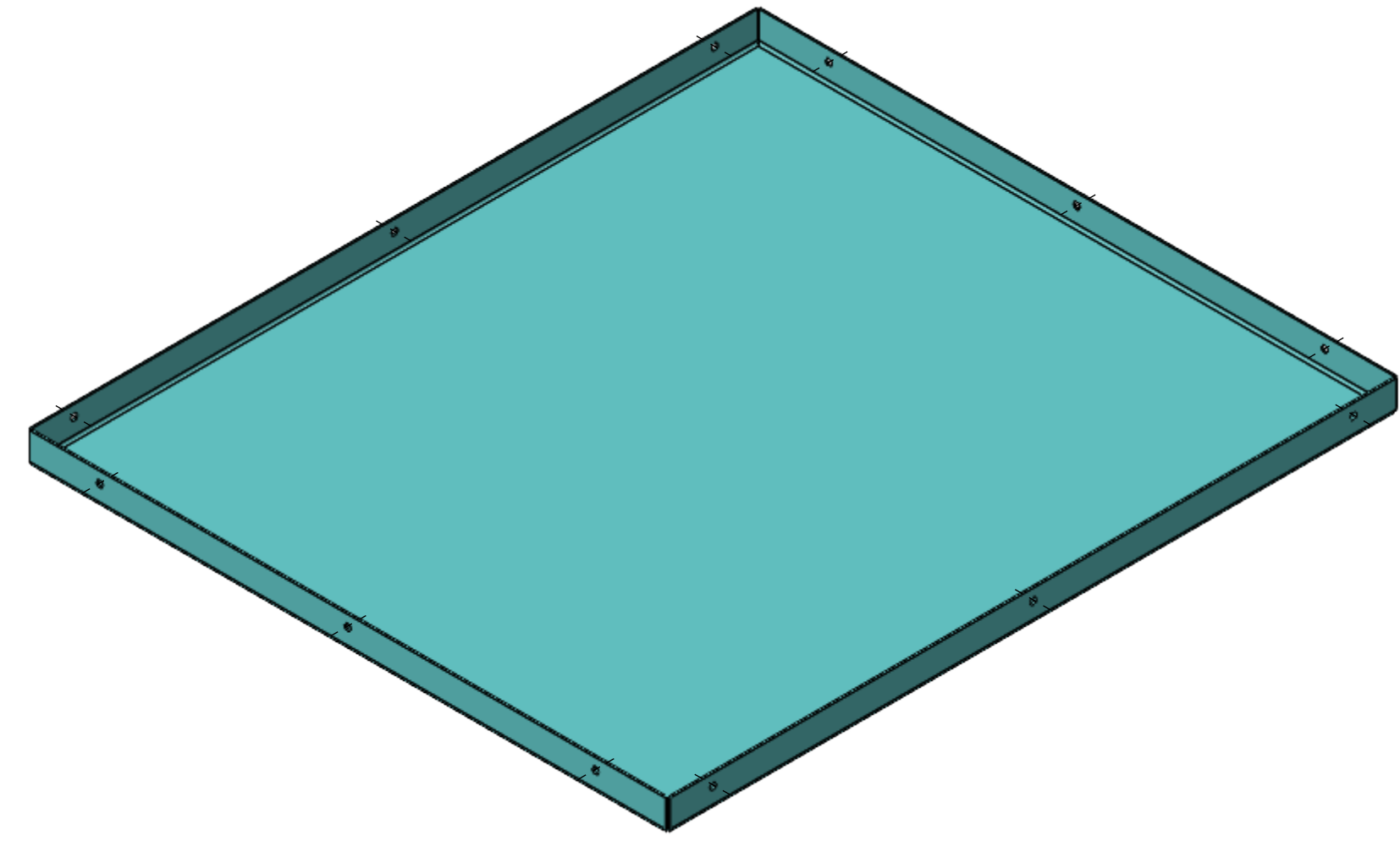
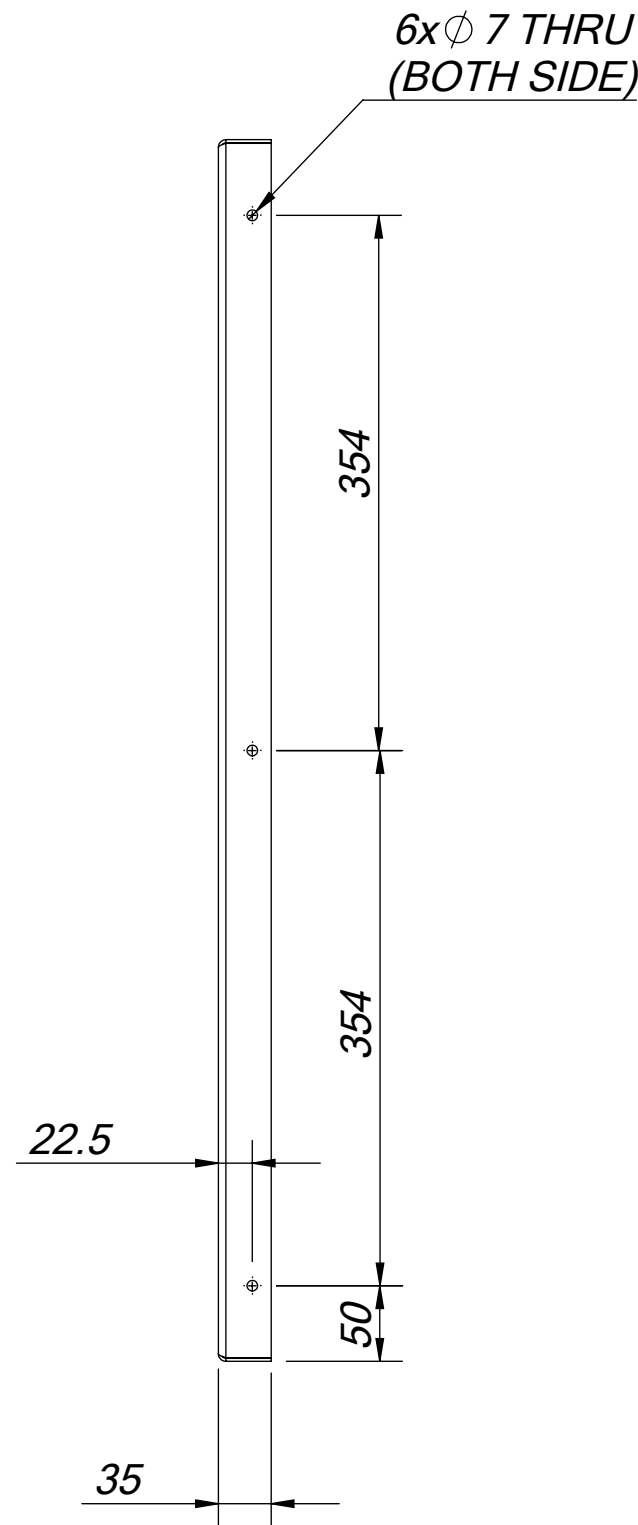
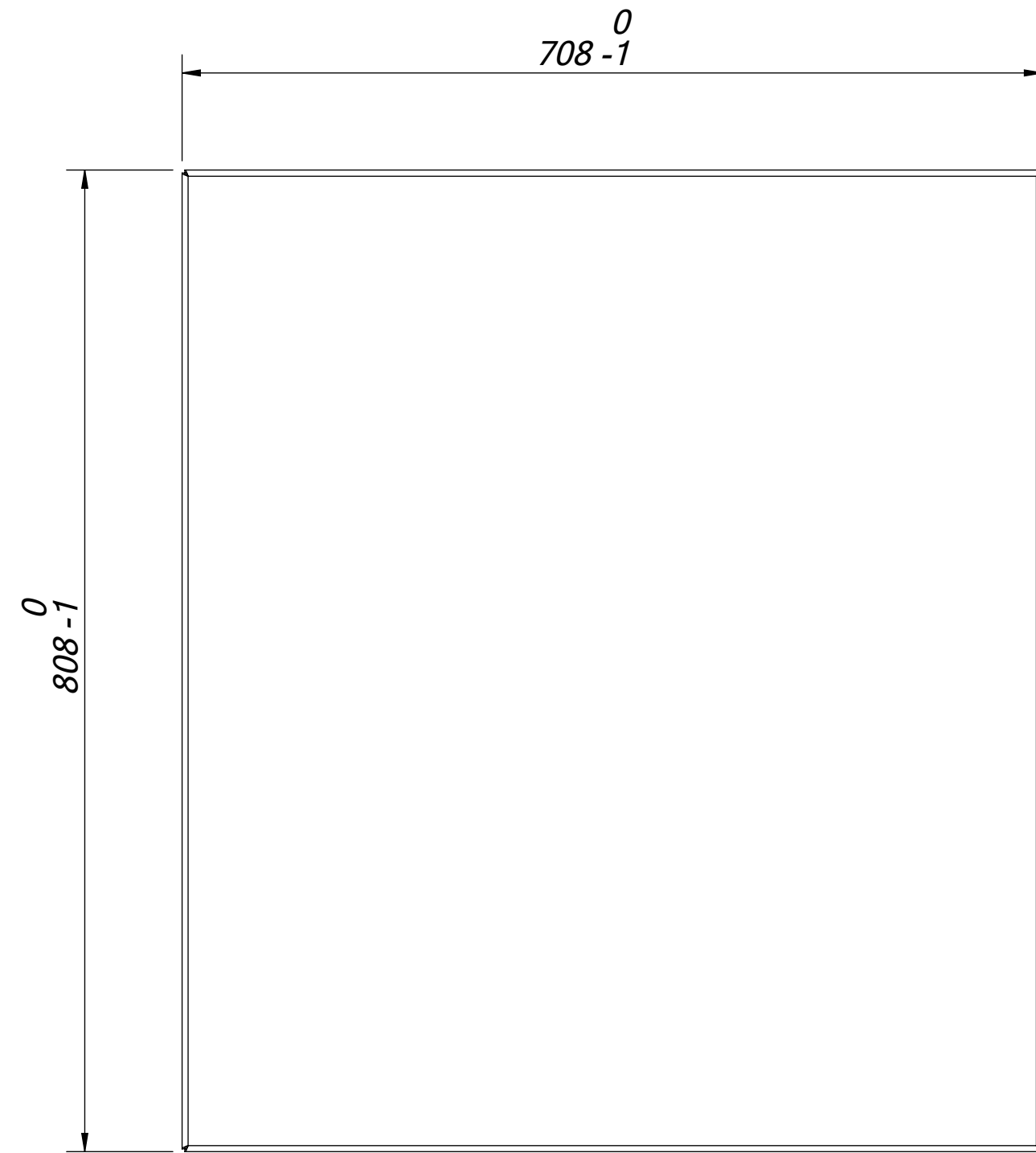
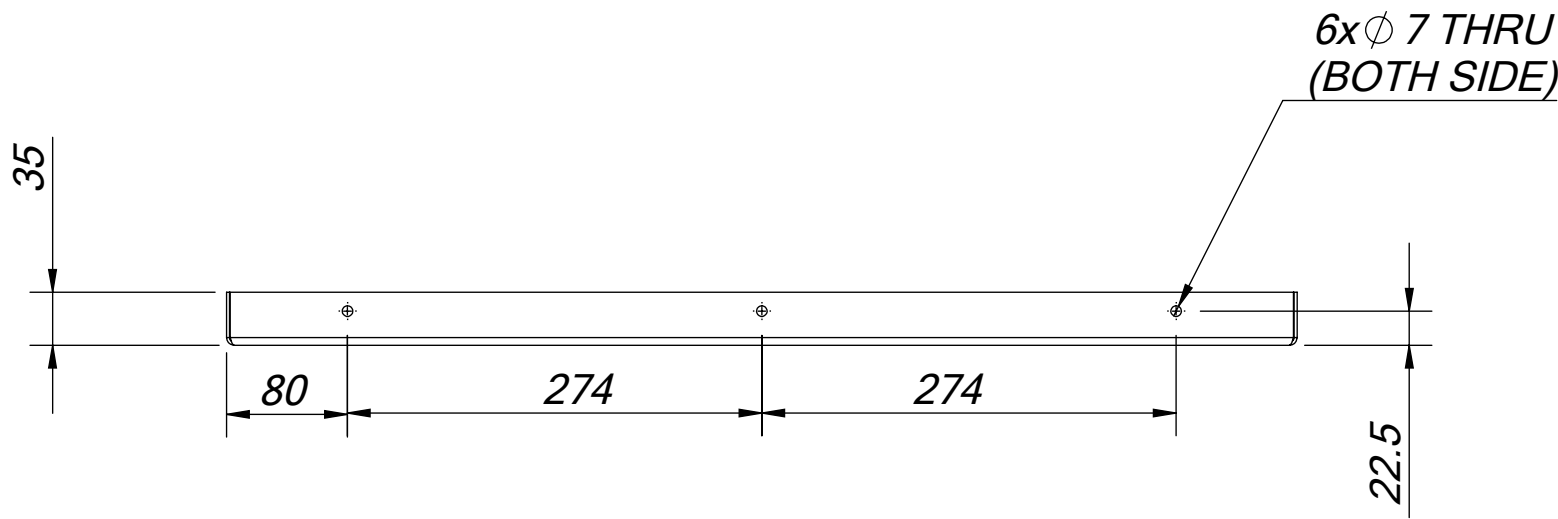

BACK SIDE COVER

NOTE:-

1. ALL DIMENIONS ARE IN MM.
2. MATERIAL- MS
3. SHEET THK.- 2 MM
4. QTY.- 1 NOS.
5. FINISH WEIGHT- 10 KG.

				PASKALS FLUID SYSTEM PVT LTD. E-148, SECTOR 63, NOIDA, UP-201301 Tel No.: 0120 4500880 Fax No.: 0120 4500888 E-mail: bd@paskals.com			
				TITLE	NOZZLE TEST SYSTEM		
SUB-TITLE	BACK SIDE COVER			Cross Ref Doc No.:			
SRS CODE	P3426			Customer Dwg Ref No.			
CUSTOMER	--			NOTE :			
END USER	--						
TD/PO. No.	--			DATED			
PROJECTION	DRWN	M.F	16/11/2024	SIZE	SCALE		
	CHK.	P.N	16/11/2024	A3	NTS		
	APPR.	S.P.S	16/11/2024				
				SHEET No	01		
				OF	01		
				NEO DWG No.			
				T-PED-P3426-MDWG-BACK SIDE COVER	00		

THIS DWG. IS SOLE PROPERTY OF PASKALS FLUID SYSTEM PVT. LTD.
 UNAUTHORISED USE OF THIS DWG. OR MAKING PRODUCT AS PER THIS
 DWG. WITHOUT OUR PERMISSION OR ANY OTHER MISUSE IS NOT
 PERMITTED.

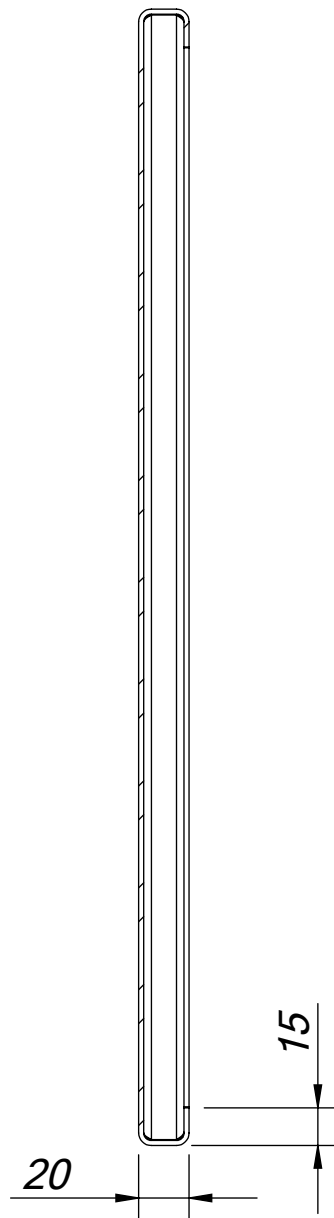
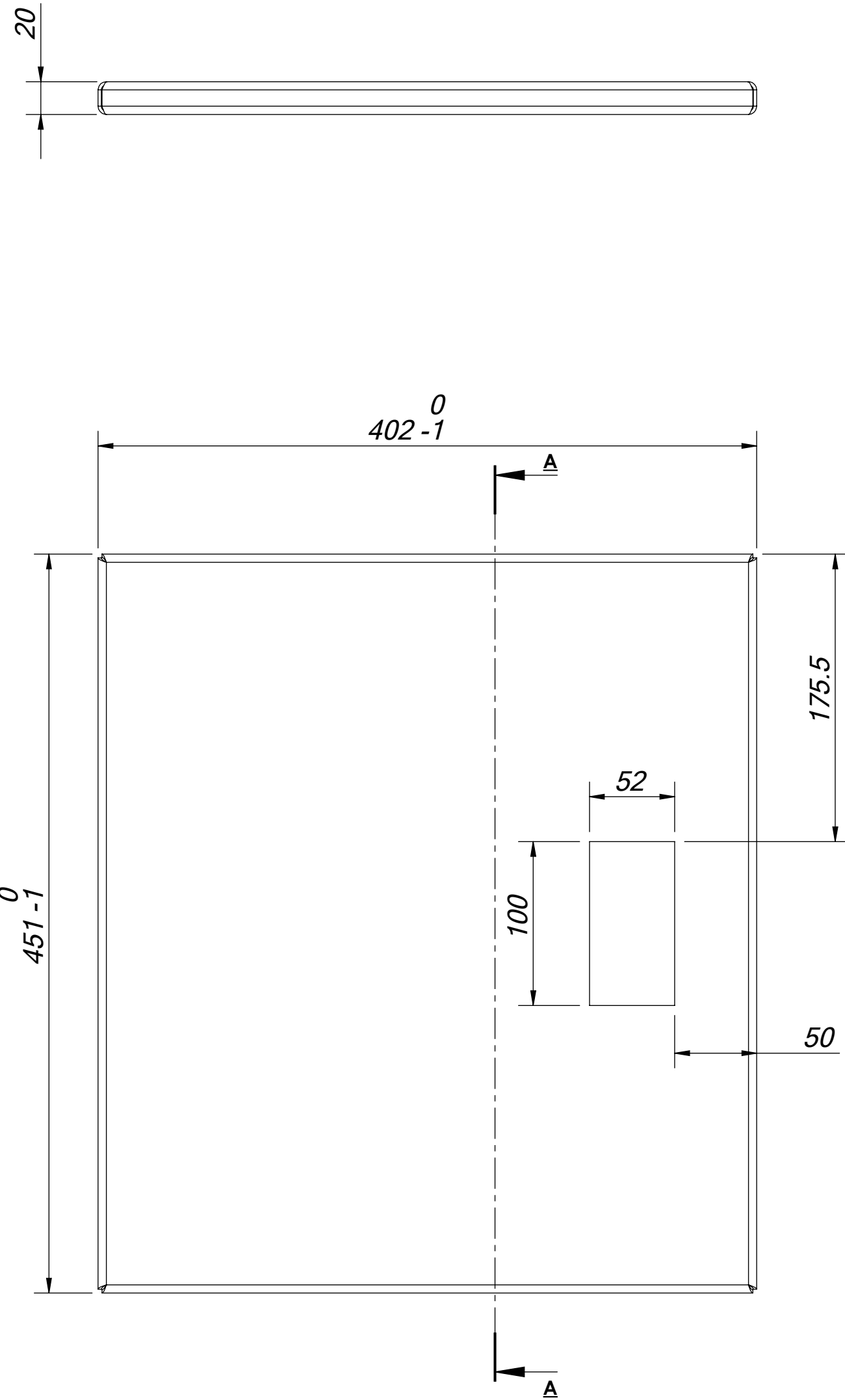

SECTION A-A

BACK SIDE DOOR

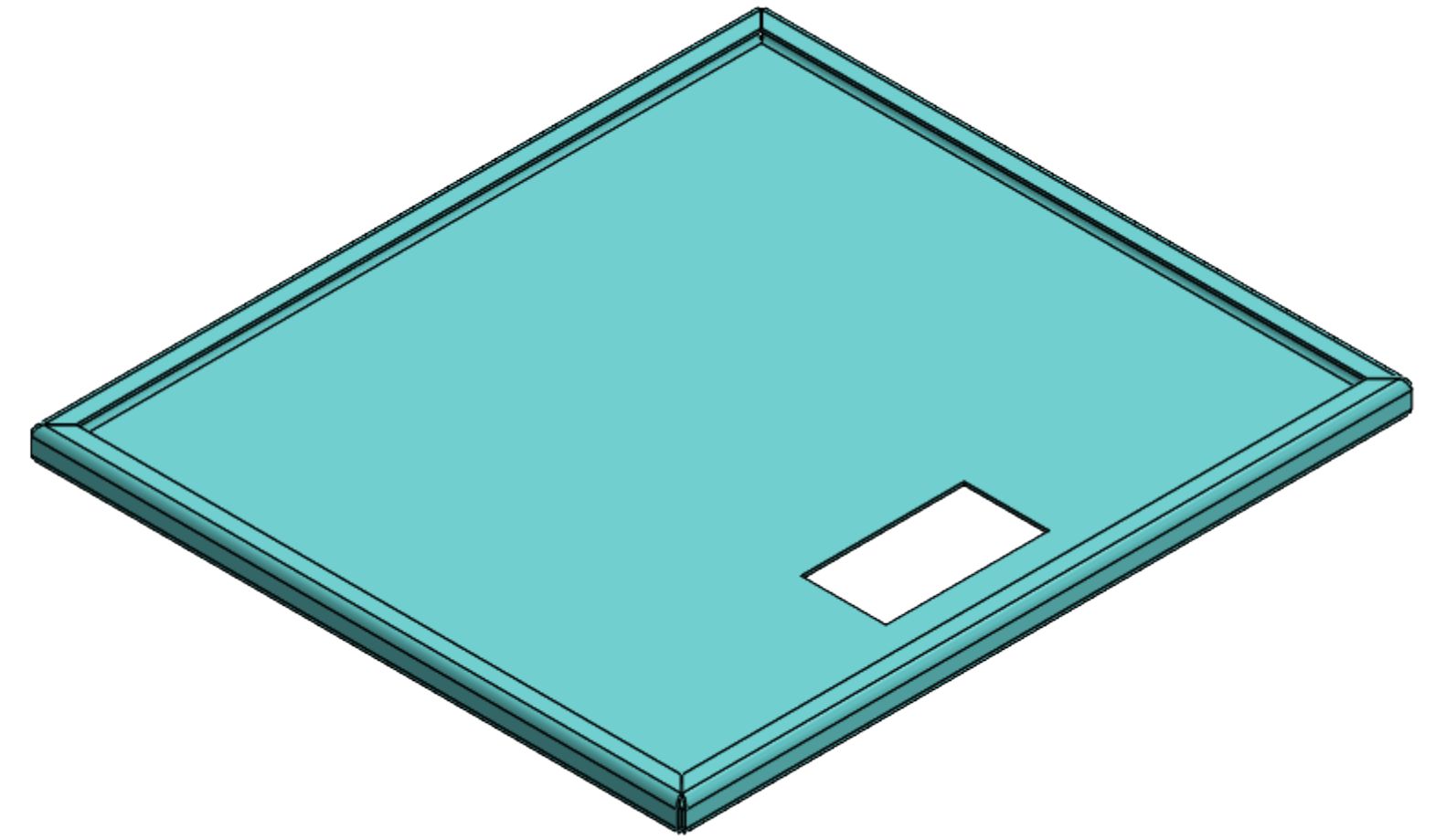

NOTE:-

1. ALL DIMENSIONS ARE IN MM.
2. MATERIAL- MS
3. SHEET THK.- 2MM
4. QTY.- 2 NOS.
5. FINISH WEIGHT- 3.5 KG.

PASKALS
Fluid Systems

PASKALS FLUID SYSTEM PVT LTD.
 E-148, SECTOR 63, NOIDA, UP-201301
 Tel No.: 0120 4500880
 Fax No.: 0120 4500888
 E-mail: bd@paskals.com

TITLE	NOZZLE TEST SYSTEM			QA No.	
SUB-TITLE	BACK SIDE DOOR			Cross Ref Doc No.:	
SRS CODE	P3426			Customer Dwg Ref No.	
CUSTOMER	--			NOTE :	
END USER	--				
TD/PO. No.	--		DATED		
PROJECTION	DRWN	M.F	16/11/2024	SIZE	SCALE
	CHK.	P.N	16/11/2024	A3	NTS
	APPR.	S.P.S	16/11/2024		
			SHEET	No	OF
			01	01	
NEO DWG No.					REV
T-PED-P3426-MDWG-BACK SIDE DOOR					00

THIS DWG. IS SOLE PROPERTY OF PASKALS FLUID SYSTEM PVT. LTD. UNAUTHORISED USE OF THIS DWG. OR MAKING PRODUCT AS PER THIS DWG. WITHOUT OUR PERMISSION OR ANY OTHER MISUSE IS NOT PERMITTED.

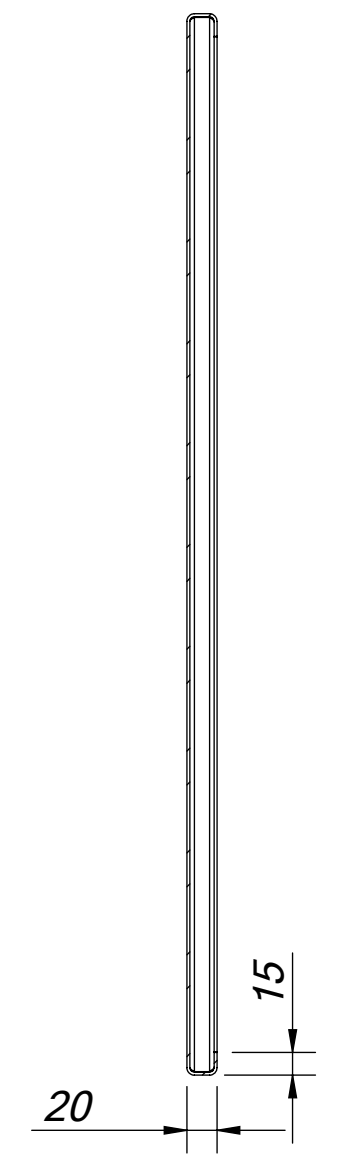
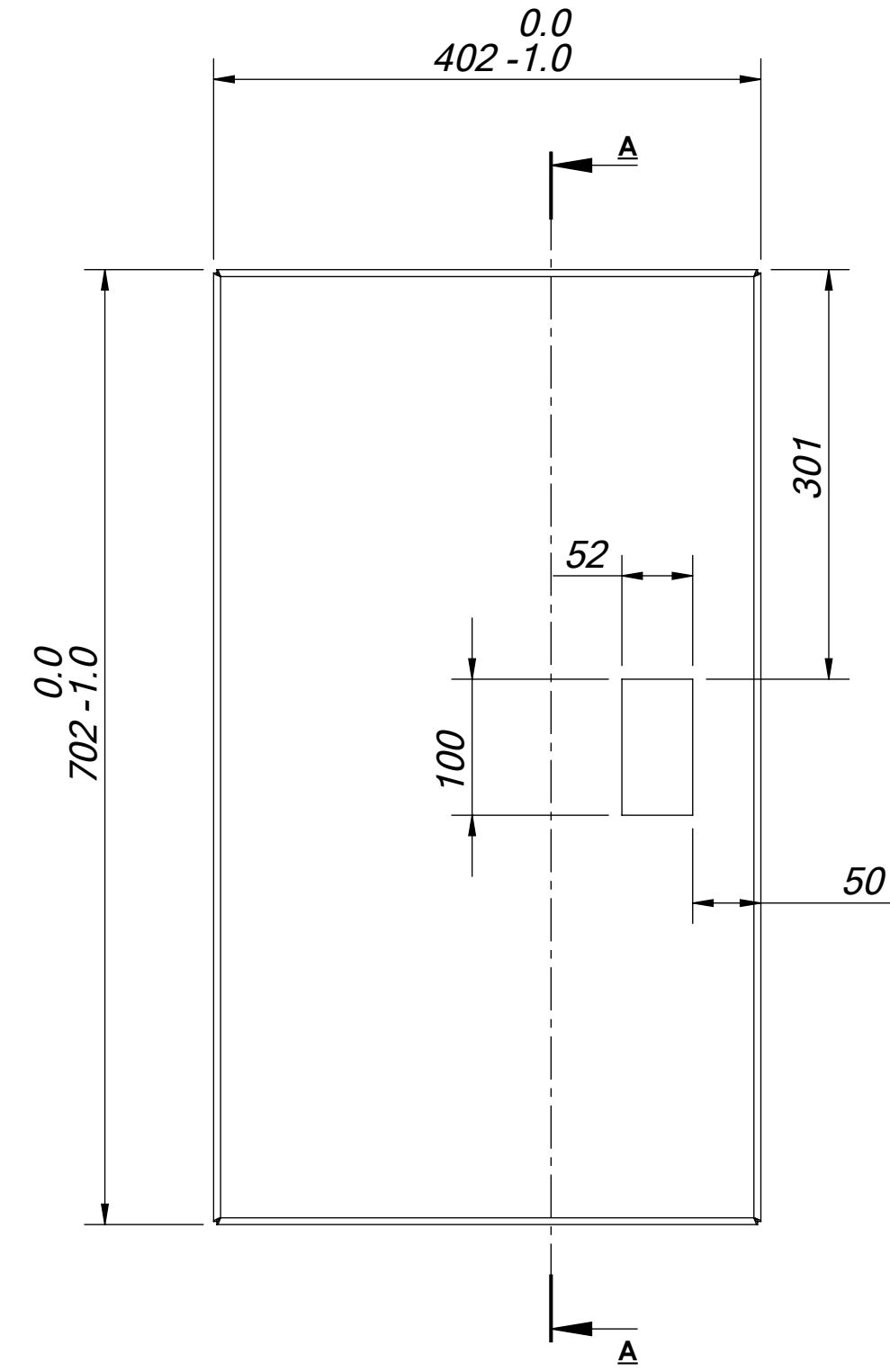

SECTION A-A

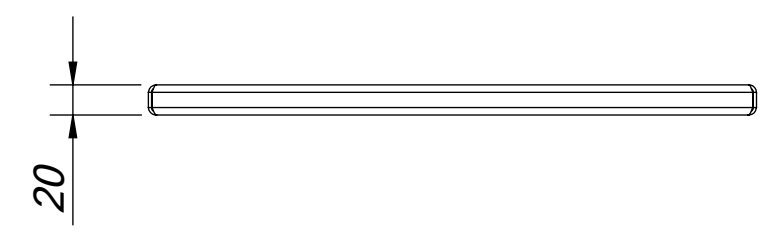
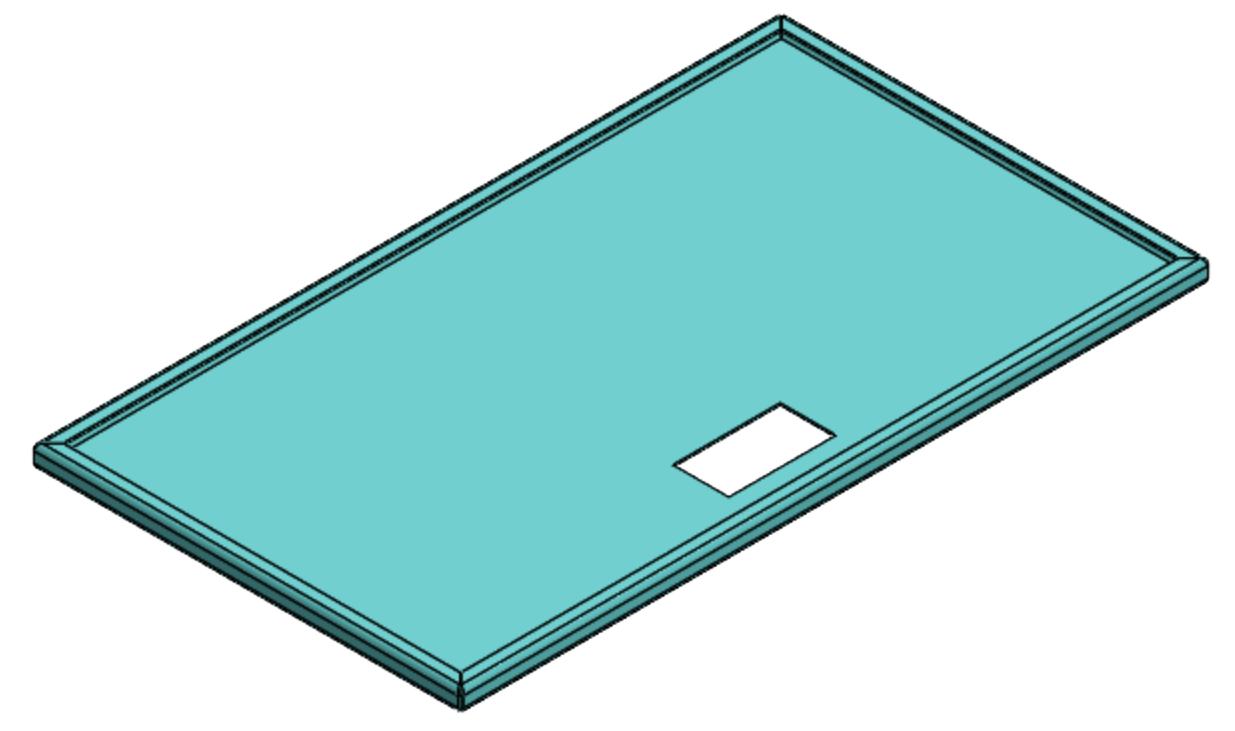

FRONT DOOR

NOTE:-

1. ALL DIMENSIONS ARE IN MM.
2. MATERIAL- MS
3. SHEET THK.- 2 MM
4. QTY.- 2 NOS.
5. FINISH WEIGHT- 5 KG.

PASKALS Fluid Systems				PASKALS FLUID SYSTEM PVT LTD. E-148, SECTOR 63, NOIDA, UP-201301 Tel No.: 0120 4500800 Fax No.: 0120 4500888 E-mail: bd@paskals.com			
TITLE	NOZZLE TEST SYSTEM			QA No.			
SUB-TITLE	FRONT DOOR			Cross Ref Doc No.:			
SRS CODE	P3426			Customer Dwg Ref No.			
CUSTOMER	--			NOTE :			
END USER	--						
TD/PO. No.	--			DATED			
PROJECTION	DRWN	M.F	16/11/2024	SIZE	SCALE	SHEET	NEO DWG No.
	CHK.	P.N	16/11/2024	A3	NTS	No OF	REV
	APPR.	S.P.S	16/11/2024			01 01	T-PED-P3426-MDWG-FRONT DOOR 00

THIS DWG. IS SOLE PROPERTY OF PASKALS FLUID SYSTEM PVT. LTD.
 UNAUTHORISED USE OF THIS DWG. OR MAKING PRODUCT AS PER THIS
 DWG. WITHOUT OUR PERMISSION OR ANY OTHER MISUSE IS NOT
 PERMITTED.

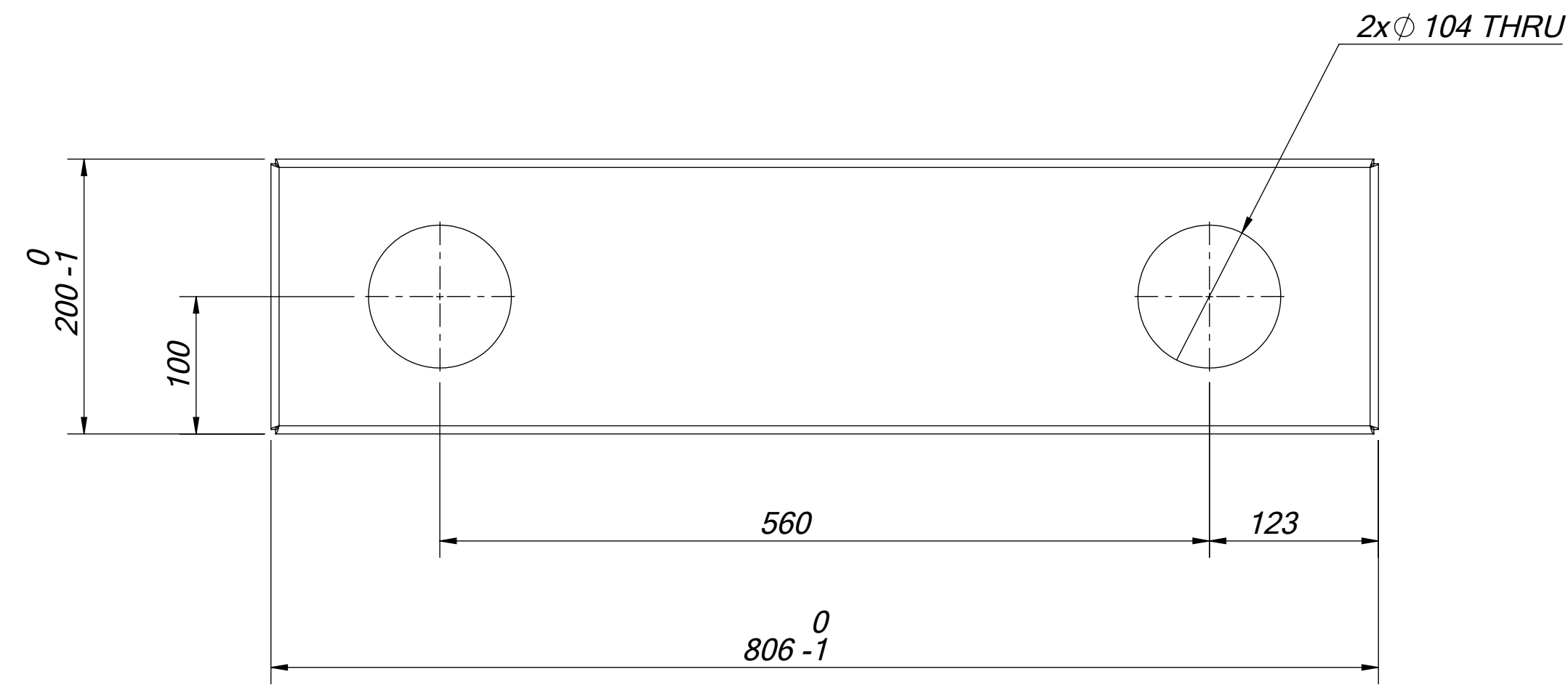
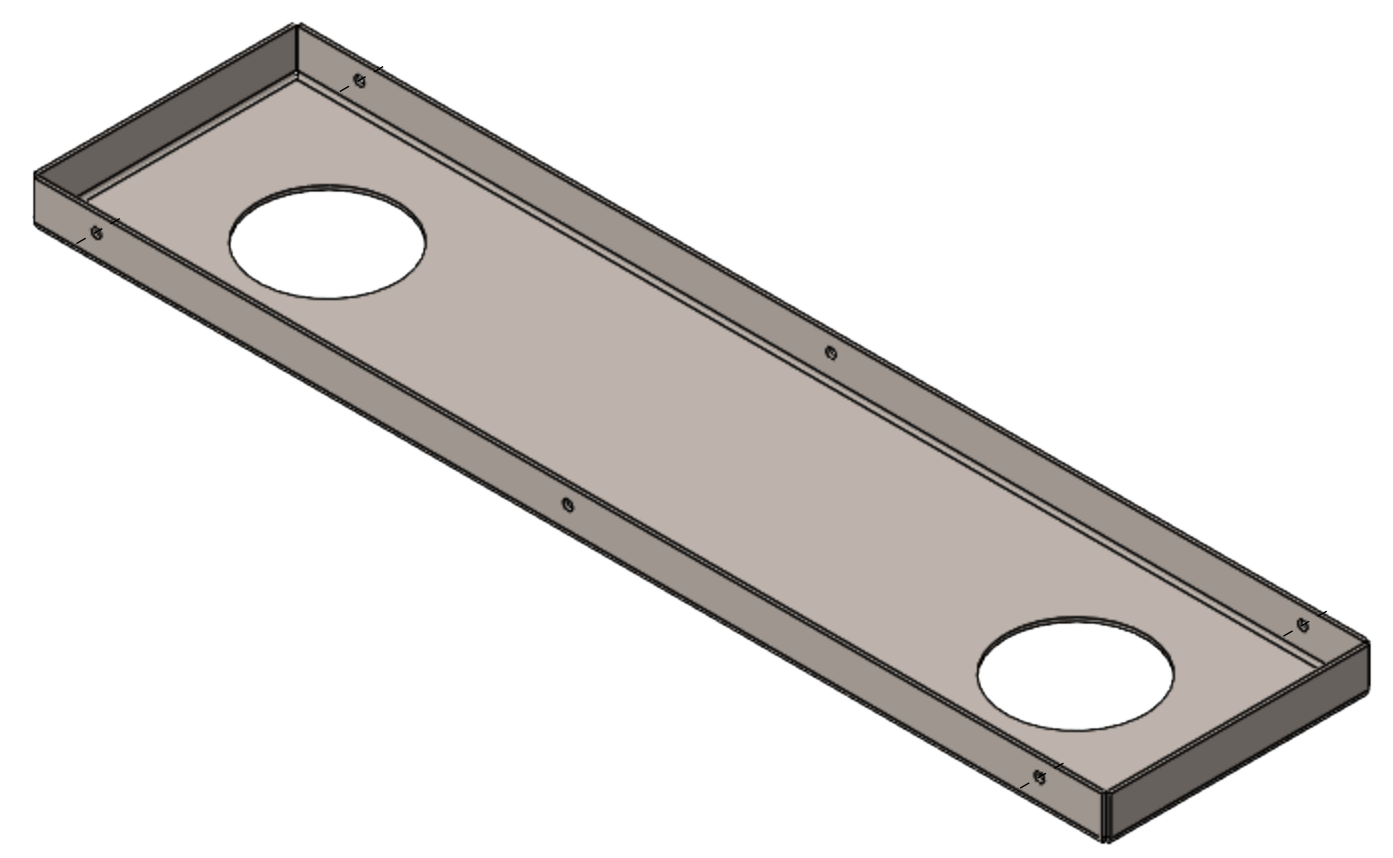
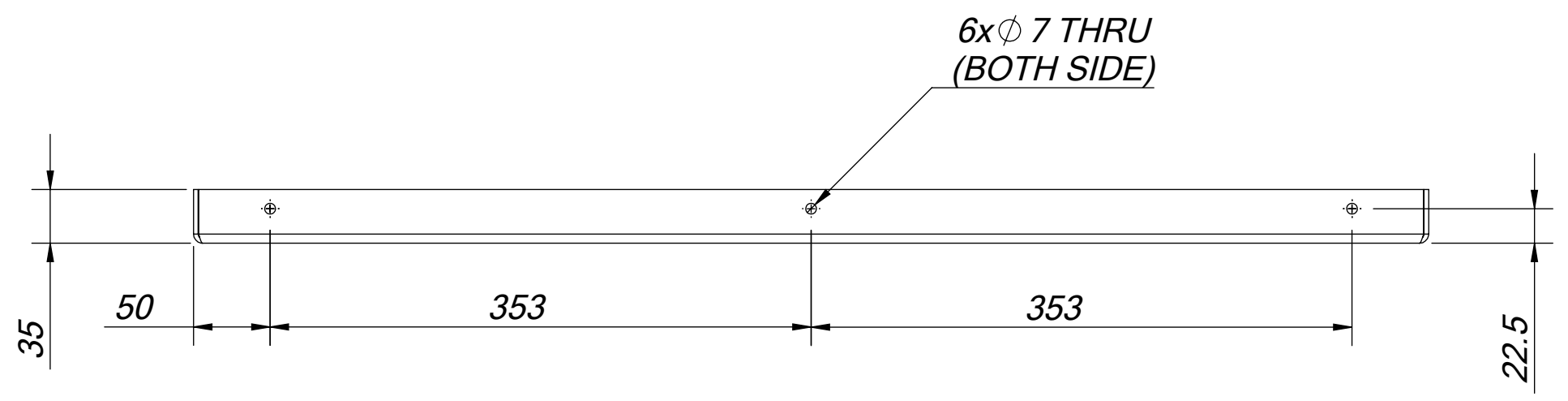

FRONT PANEL

NOTE:-

1. ALL DIMENSIONS ARE IN MM.
2. MATERIAL- SS-304
3. SHEET THK.- 3 MM
4. QTY.- 1 NOS.
5. FINISH WEIGHT- 5 KG.

PASKALS Fluid Systems		PASKALS FLUID SYSTEM PVT LTD. E-148, SECTOR 63, NOIDA, UP-201301 Tel No.: 0120 4500880 Fax No.: 0120 4500888 E-mail: bd@paskals.com			
TITLE	NOZZLE TEST SYSTEM			QA No.	
SUB-TITLE	FRONT PANEL			Cross Ref Doc No.:	
SRS CODE	P3426			Customer Dwg Ref No.	
CUSTOMER	--			NOTE :	
END USER	--				
TD/PO. No.	--			DATED	
PROJECTION	DRWN	M.F	16/11/2024	SIZE	SCALE
	CHK.	P.N	16/11/2024	A3	NTS
	APPR.	S.P.S	16/11/2024		
				SHEET No	01
				OF	01
				NEO DWG No.	
				REV	00
				T-PED-P3426-MDWG-FRONT PANEL	

THIS DWG. IS SOLE PROPERTY OF PASKALS FLUID SYSTEM PVT. LTD. UNAUTHORISED USE OF THIS DWG. OR MAKING PRODUCT AS PER THIS DWG. WITHOUT OUR PERMISSION OR ANY OTHER MISUSE IS NOT PERMITTED.

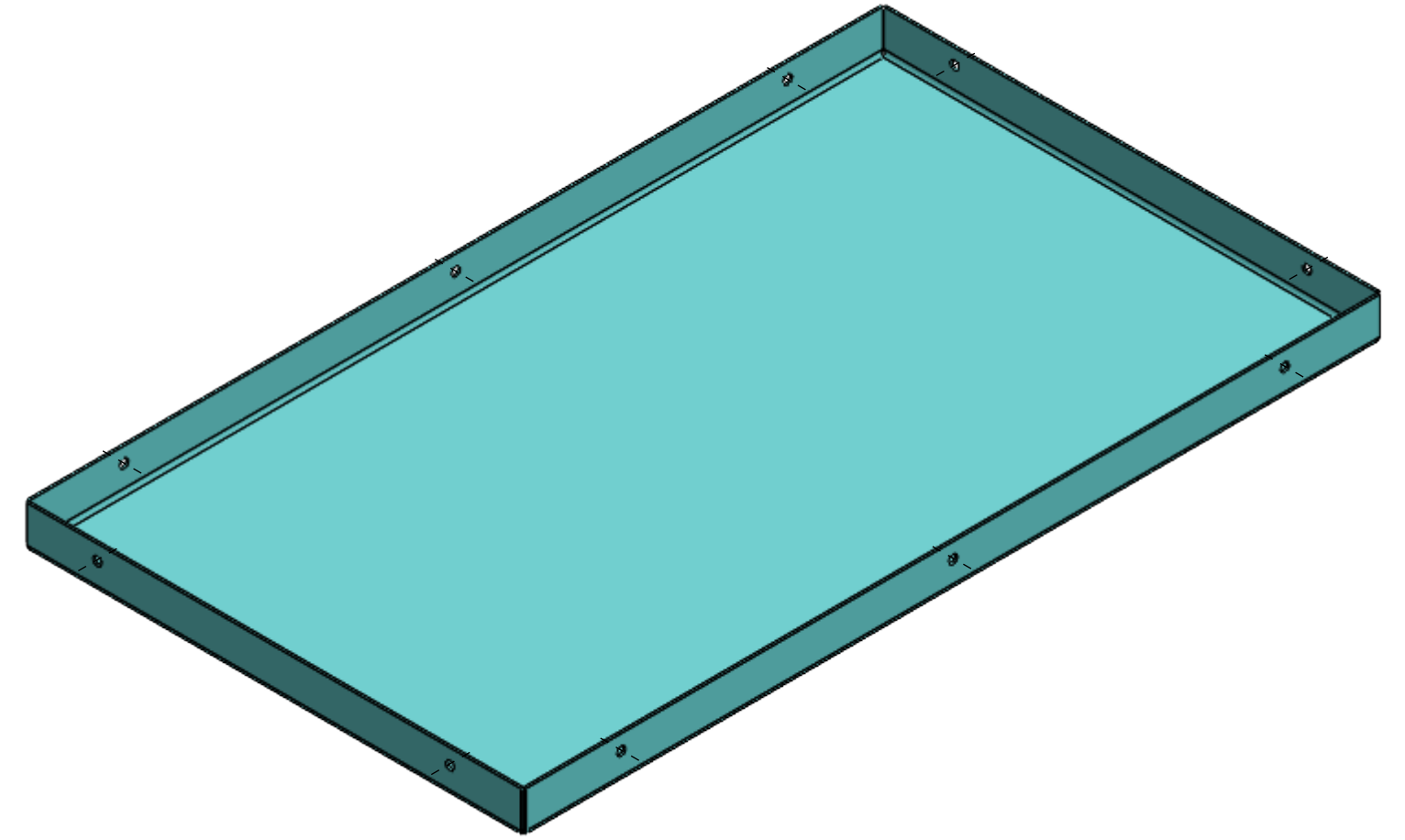
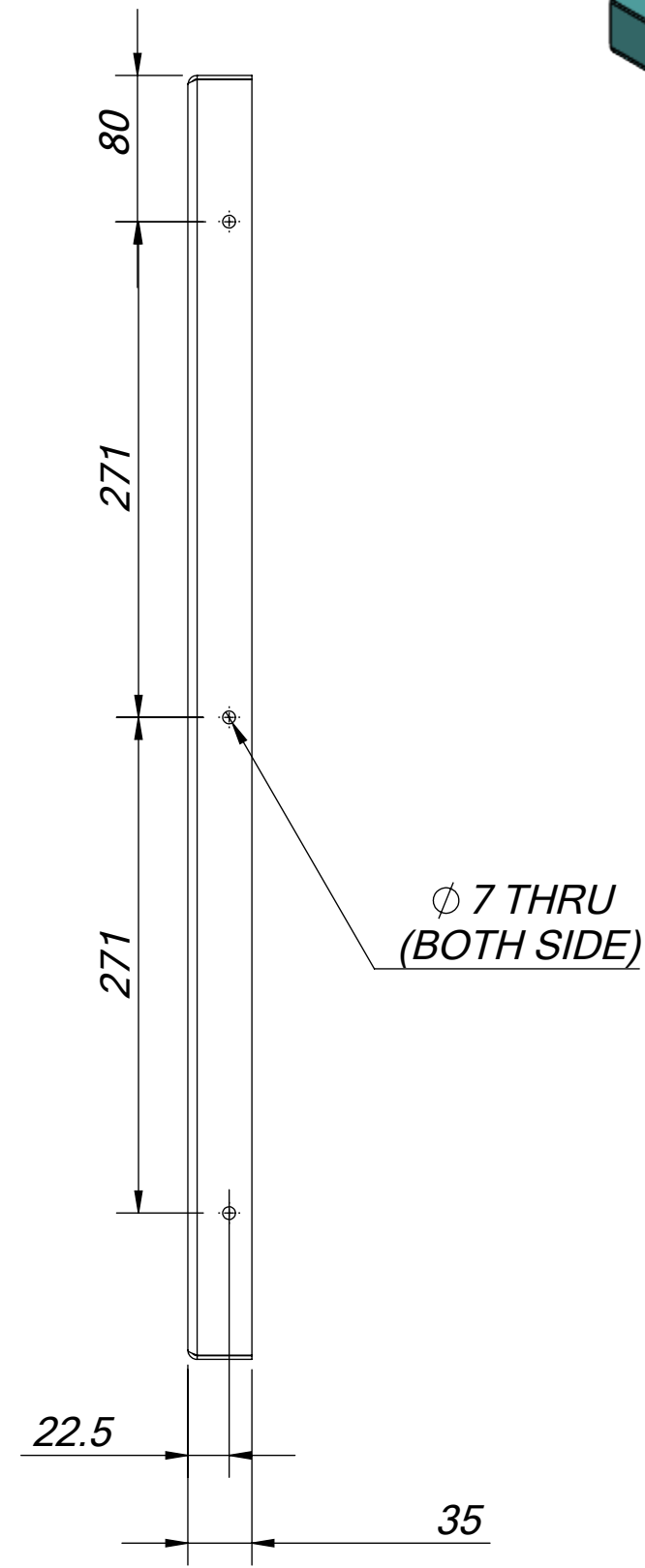
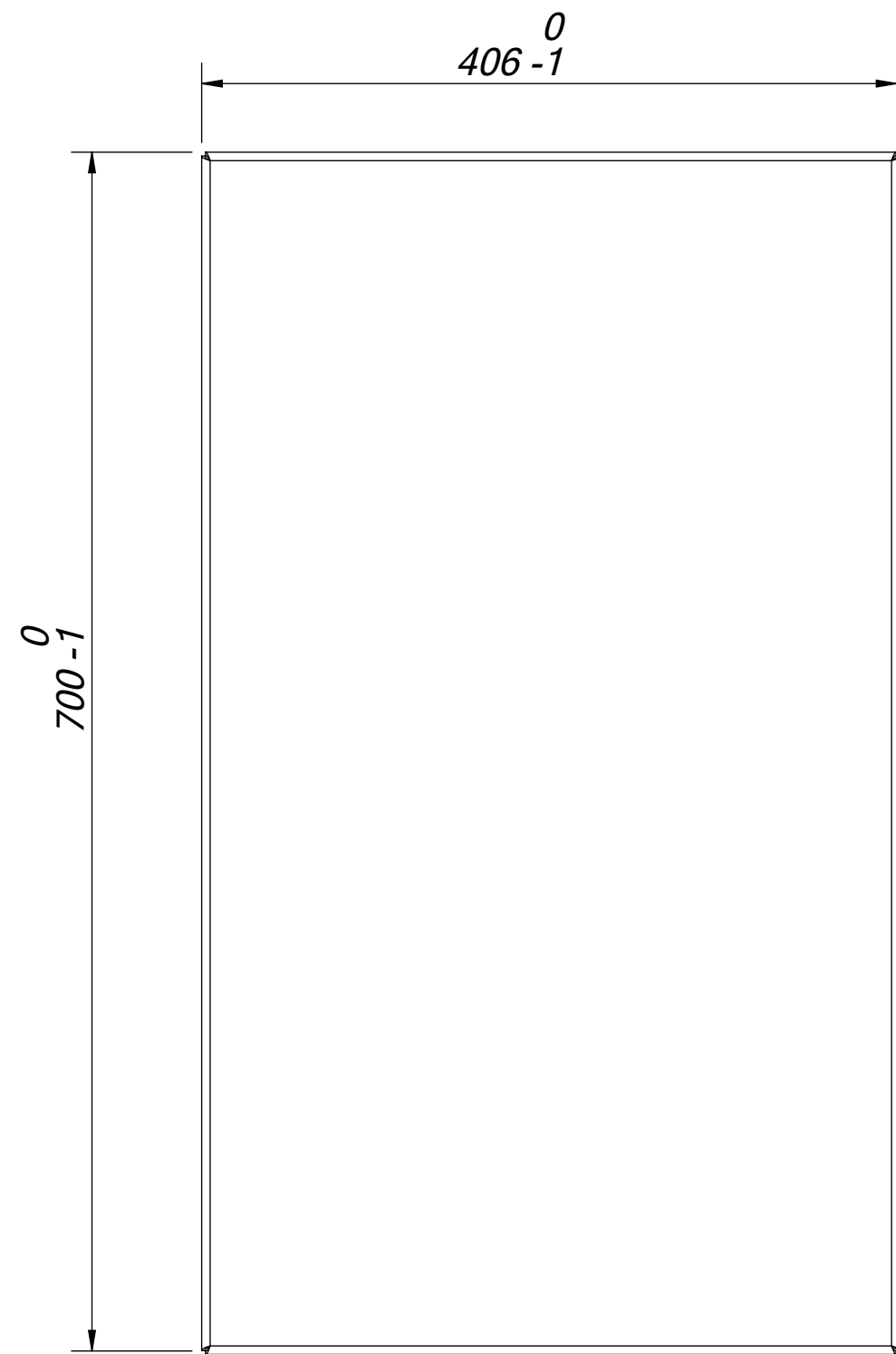
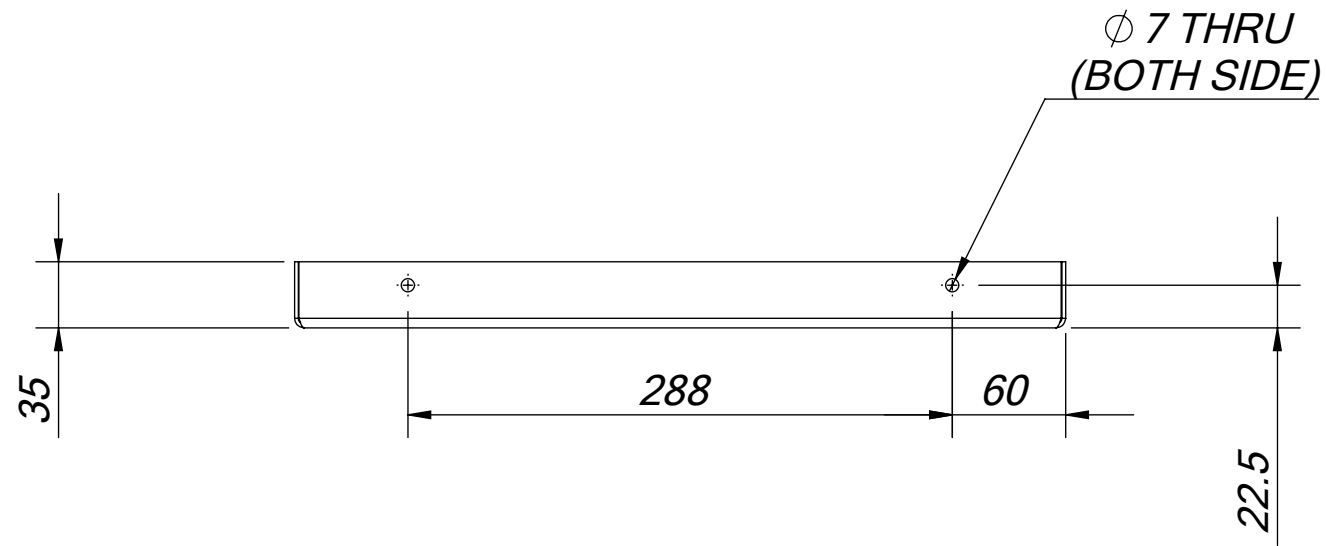

NOTE:-

1. ALL DIMENSIONS ARE IN MM.
2. MATERIAL- MS
3. SHEET THK. 2 MM
4. QTY.- 2 NOS.
5. FINISH WEIGHT- 5.5 KG.

BOTTOM LEFT & RIGHT SIDE COVER

PASKALS Fluid Systems		PASKALS FLUID SYSTEM PVT LTD. E-148, SECTOR 63, NOIDA, UP-201301 Tel No.: 0120 4500880 Fax No.: 0120 4500888 E-mail: bd@paskals.com	
TITLE	NOZZLE TEST SYSTEM		QA No.
SUB-TITLE	BOTTOM LEFT & RIGHT SIDE COVER		Cross Ref Doc No.:
SRS CODE	P3426		Customer Dwg Ref No.
CUSTOMER	--		NOTE :
END USER	--		
TD/PO. No.	--	DATED	
PROJECTION	DRWN	M.F	16/11/2024
	CHK.	P.N	16/11/2024
	APPR.	S.P.S	16/11/2024
SIZE	SCALE	SHEET No OF	NEO DWG No.
A3	NTS	01 01	T-DAP-P3426-MDWG-BOTTO L&R COVER
			REV
			00

THIS DWG. IS SOLE PROPERTY OF PASKALS FLUID SYSTEM PVT. LTD. UNAUTHORISED USE OF THIS DWG. OR MAKING PRODUCT AS PER THIS DWG. WITHOUT OUR PERMISSION OR ANY OTHER MISUSE IS NOT PERMITTED.

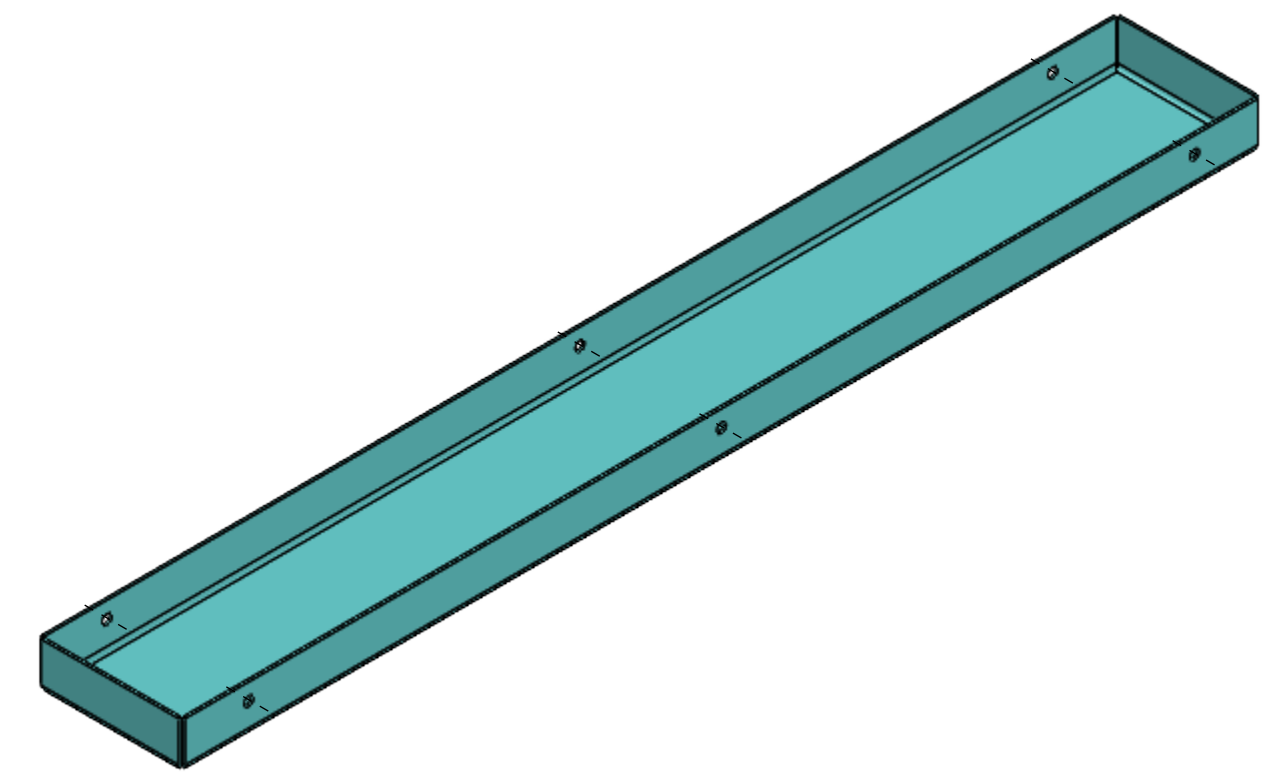
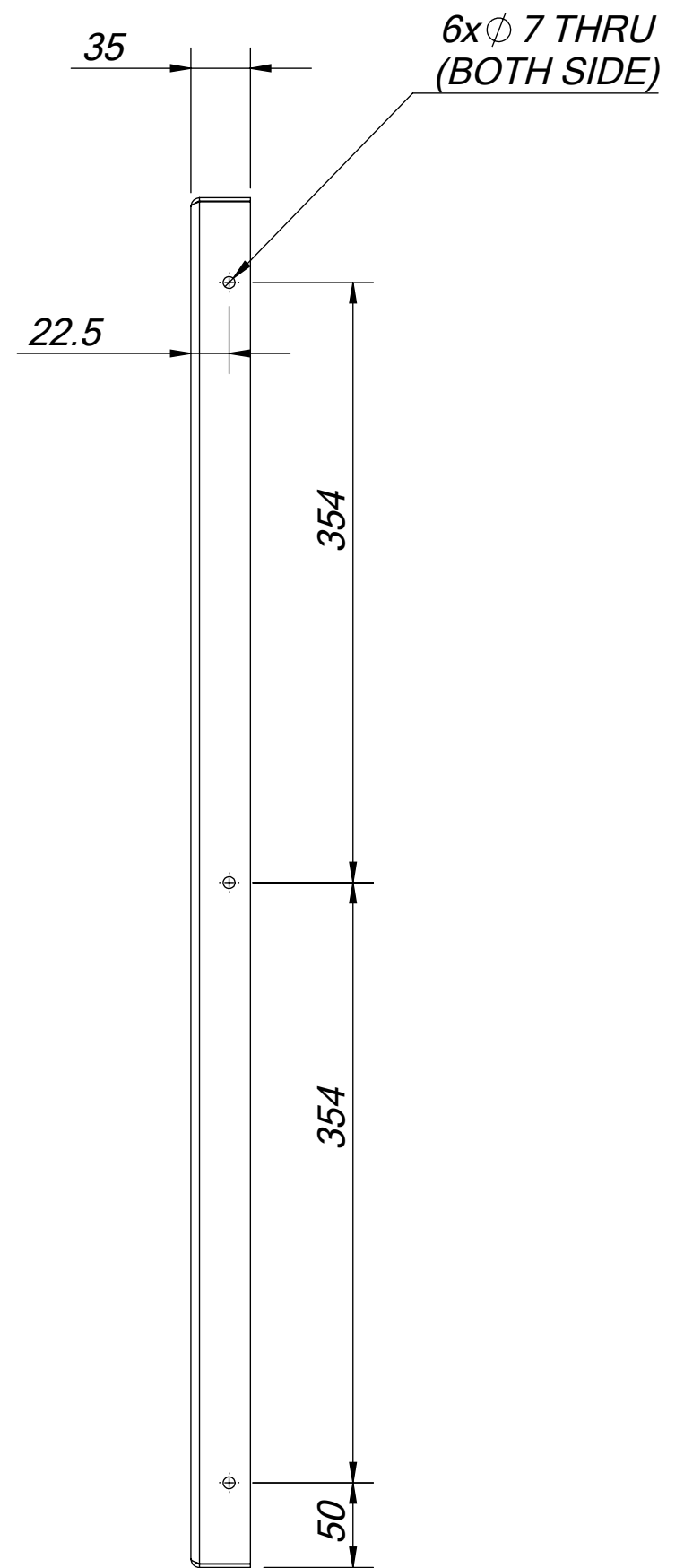
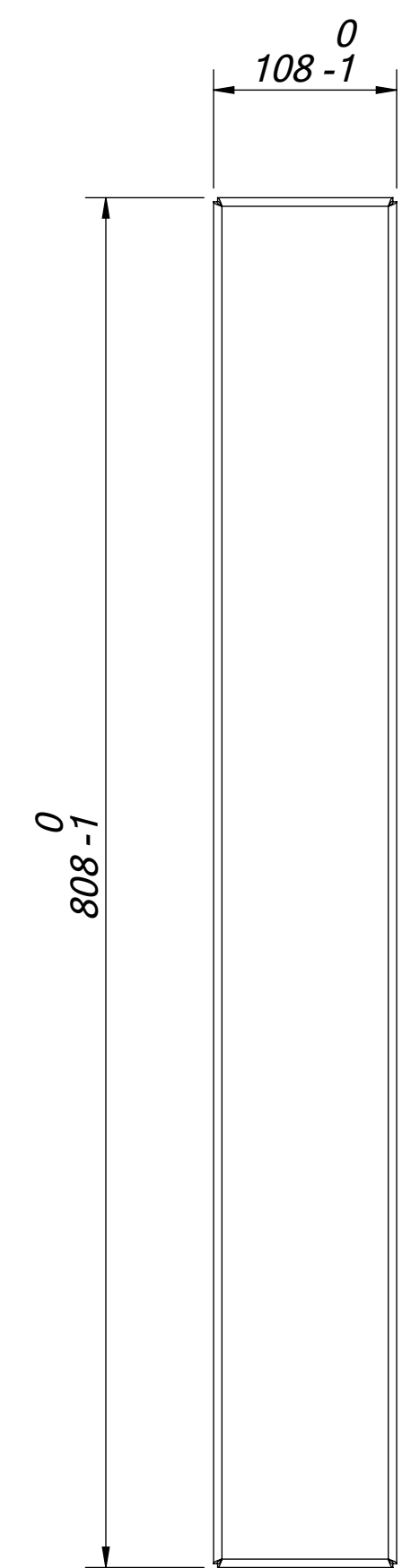
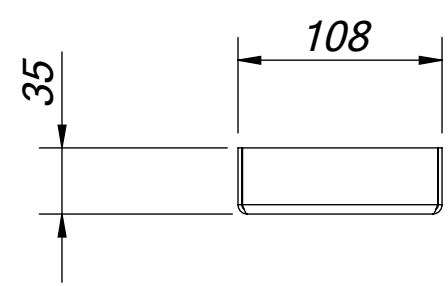

- NOTE:-
1. ALL DIMENSIONS ARE IN MM.
 2. MATERIAL- MS
 3. SHEET THK.- 2 MM
 4. QTY.- 1 NOS.
 5. FINISH WEIGHT-

TOP COVER

PASKALS Fluid Systems		PASKALS FLUID SYSTEM PVT LTD. E-148, SECTOR 63, NOIDA, UP-201301 Tel No.: 0120 4500880 Fax No.: 0120 4500888 E-mail: bd@paskals.com			
TITLE	NOZZLE TEST SYSTEM			QA No.	
SUB-TITLE	TOP COVER			Cross Ref Doc No.:	
SRS CODE	P3426			Customer Dwg Ref No.	
CUSTOMER	--			NOTE :	
END USER	--				
TD/PO. No.	--			DATED	
PROJECTION	DRWN	M.F	16/11/2024	SIZE	SCALE
	CHK.	P.N	16/11/2024	A3	NTS
	APPR.	S.P.S	16/11/2024		
				SHEET No	01
				OF	01
				NEO DWG No.	
				T-PED-A3426-MDWG-TOP COVER	00

THIS DWG. IS SOLE PROPERTY OF PASKALS FLUID SYSTEM PVT. LTD. UNAUTHORISED USE OF THIS DWG. OR MAKING PRODUCT AS PER THIS DWG. WITHOUT OUR PERMISSION OR ANY OTHER MISUSE IS NOT PERMITTED.

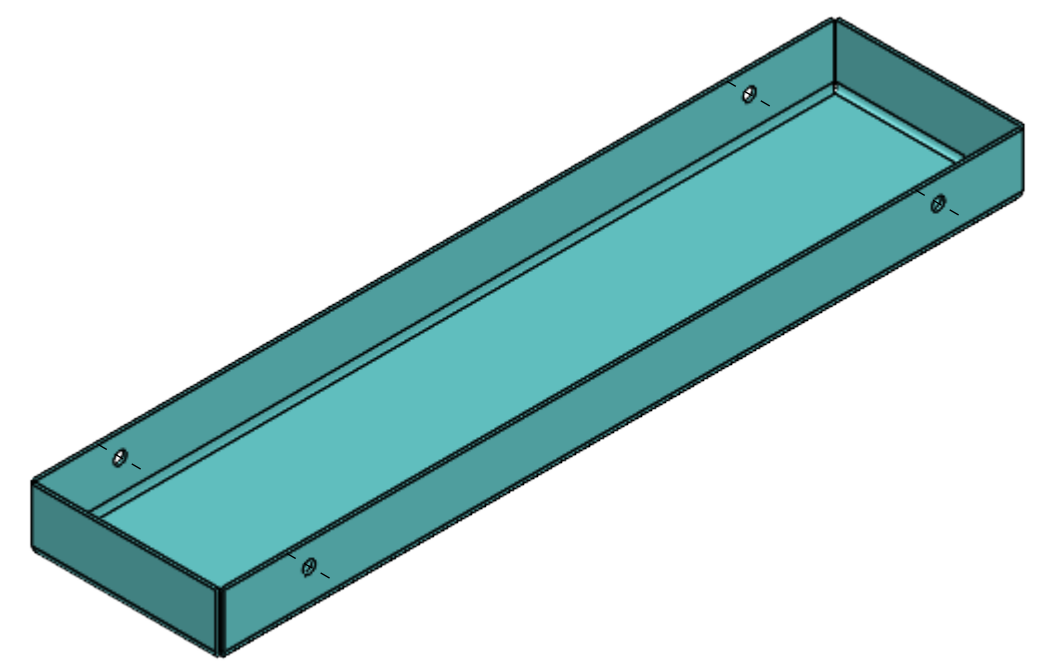
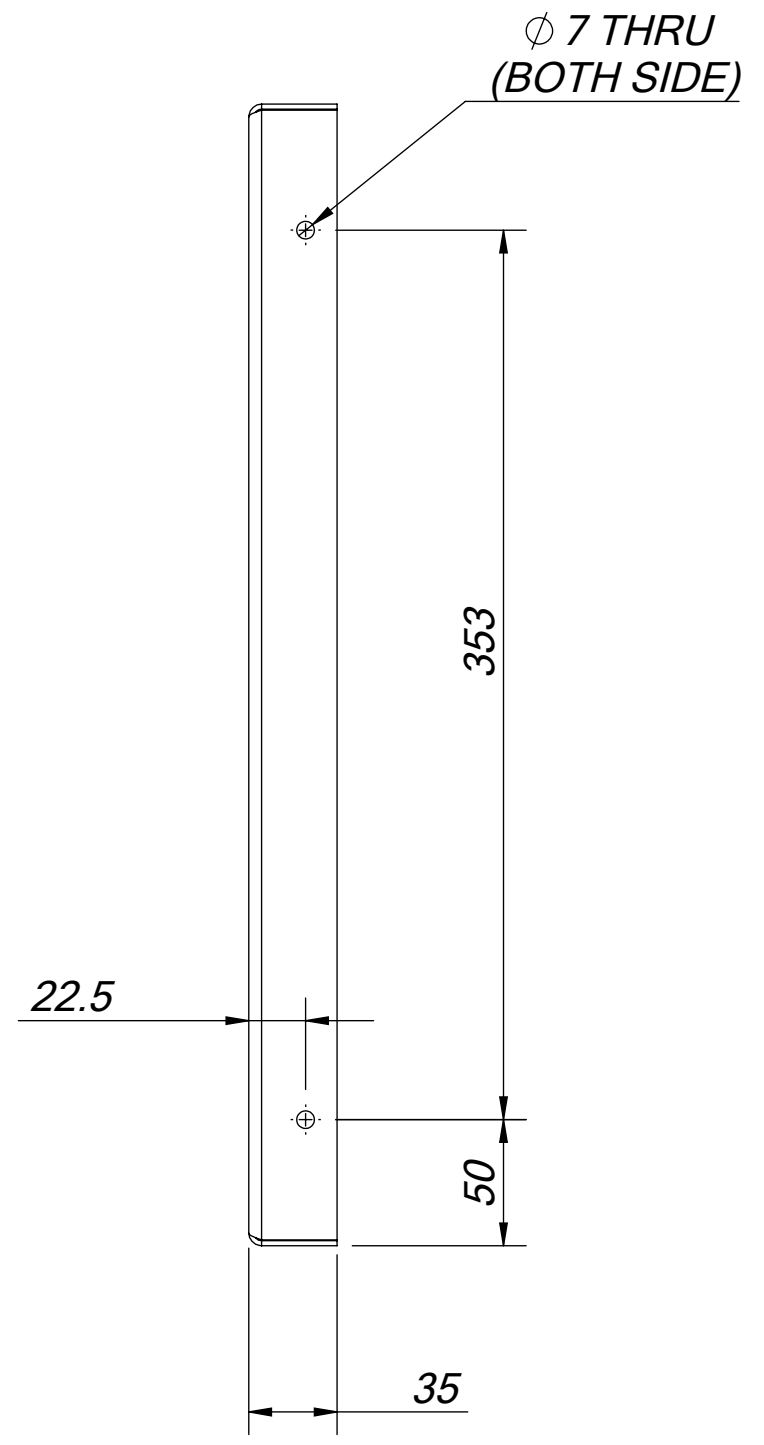
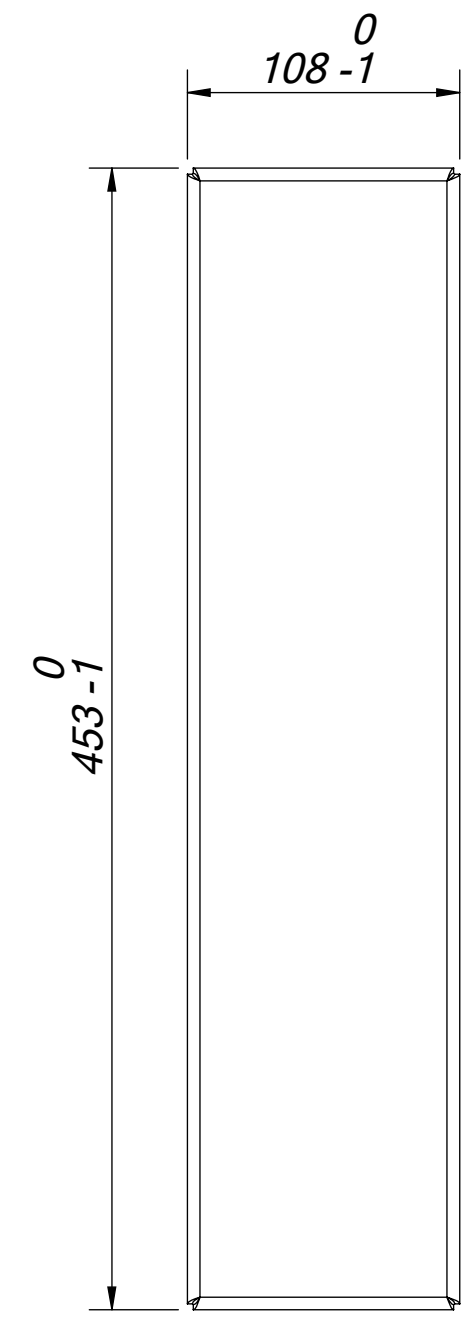
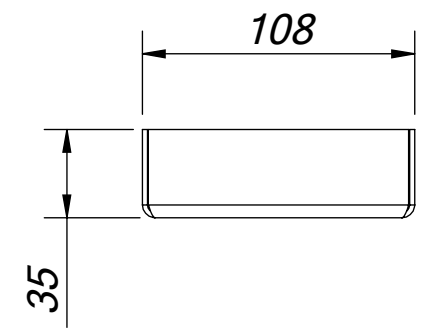

NOTE:-

1. ALL DIMENIONS ARE IN MM.
2. MATERIAL- MS
3. SHEET THK.- 2 MM
4. QTY.- 2 NOS.
5. FINISH WEIGHT- 1 KG.

TOP LEFT & RIGHT SIDE COVER

PASKALS Fluid Systems		PASKALS FLUID SYSTEM PVT LTD. E-148, SECTOR 63, NOIDA, UP-201301 Tel No.: 0120 4500880 Fax No.: 0120 4500888 E-mail: bd@paskals.com			
TITLE	NOZZLE TEST SYSTEM			QA No.	
SUB-TITLE	TOP LEFT & RIGHT SIDE COVER			Cross Ref Doc No.:	
SRS CODE	P3426			Customer Dwg Ref No.	
CUSTOMER	--			NOTE :	
END USER	--				
TD/PO. No.	--		DATED		
PROJECTION	DRWN	M.F	16/11/2024	SIZE	SCALE
	CHK.	P.N	16/11/2024	A3	NTS
	APPR.	S.P.S	16/11/2024		
			SHEET No	01	OF 01
			NEO DWG No.		
			T-DAP-P3426-MDWG- TOP L&R COVER	REV	00