

THIS DWG. IS SOLE PROPERTY OF PASKALS FLUID SYSTEMS PVT. LTD.
 UNAUTHORISED USE OF THIS DWG. OR MAKING PRODUCT AS PER THIS DWG.
 WITHOUT OUR PERMISSION OR ANY OTHER MISUSE IS NOT PERMITTED.

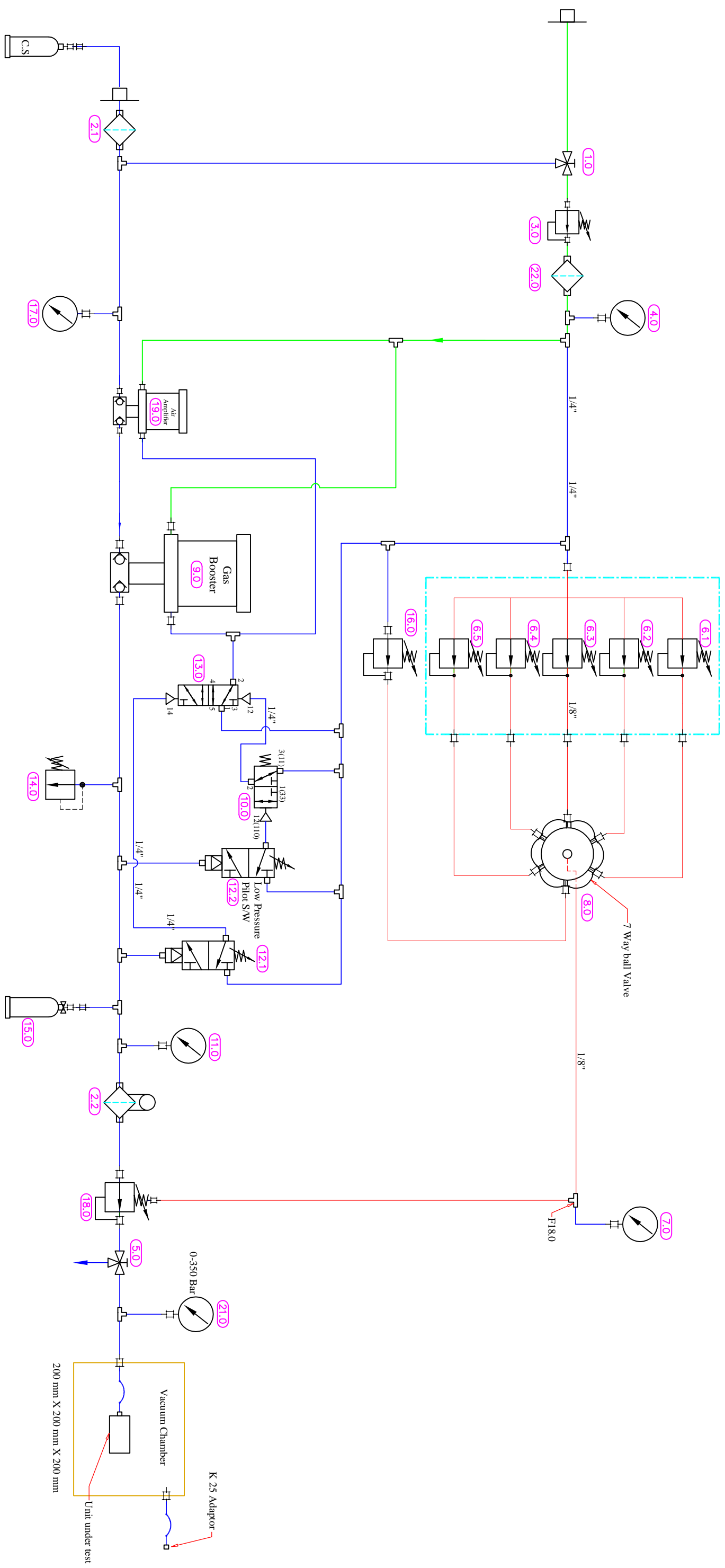

Color	Tube Size(In)
Blue	1/4"
Green	1/2"
Red	1/8"

PASKALS
 Advanced Fluid Systems

PASKALS FLUID SYSTEMS PRIVATE LIMITED
 E-148, SECTOR-65, NOIDA-201301 (U.P.)
 Tel: Phone No. 0120-2600800
 E-Mail: Customer@paskals.in

MAIN-TITLE	Pressure PAC	O.A. No.	
SUB - TITLE	PNEUMATIC CIRCUIT DIAGRAM	CROSSER DOC.	
CODE	PM695	CUSTOMER DWG. REF. NO.	
CUSTOMER	BAUMER	NOTES	
END USER	BAUMER		
APPLICATION			
DRAWN BY & DATE	SK 23/07/2014	SHEET SCALE	SHEET PASKALS DWG. NO.
CHECKED BY & DATE	SSS 23/07/2014	NO. OF	REV.
APPROVED BY & DATE	SSS 23/07/2014	A4	NTS
		01	1:1
		02	1:1
		03	1:1
		04	1:1
		05	1:1
		06	1:1
		07	1:1
		08	1:1
		09	1:1
		10	1:1
		11	1:1
		12	1:1