

THIS DWG. IS SOLE PROPERTY OF PASKALS FLUID SYSTEM PVT. LTD. UNAUTHORISED USE OF THIS DWG. OR MAKING PRODUCT AS PER THIS DWG. WITHOUT OUR PERMISSION OR ANY OTHER MISUSE IS NOT PERMITTED.

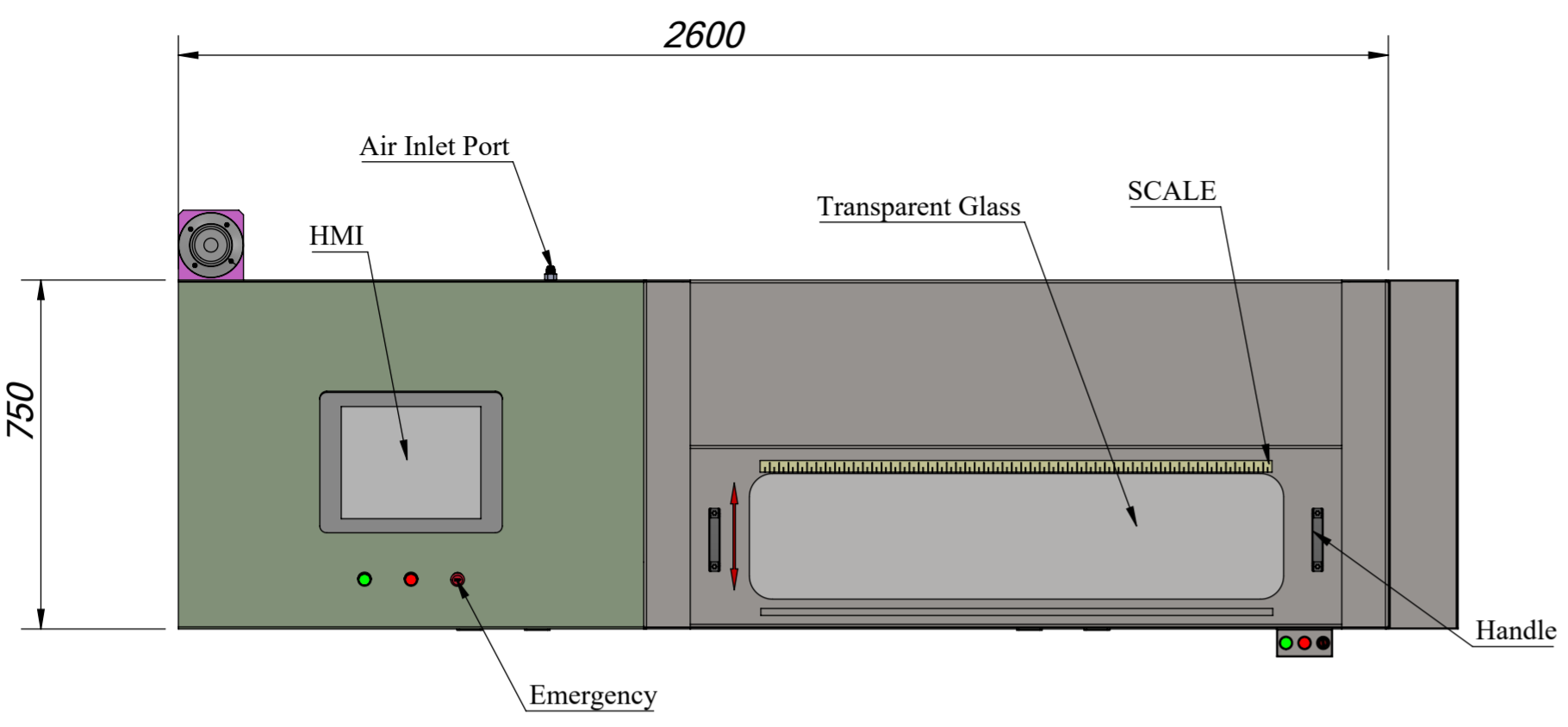

TOP VIEW

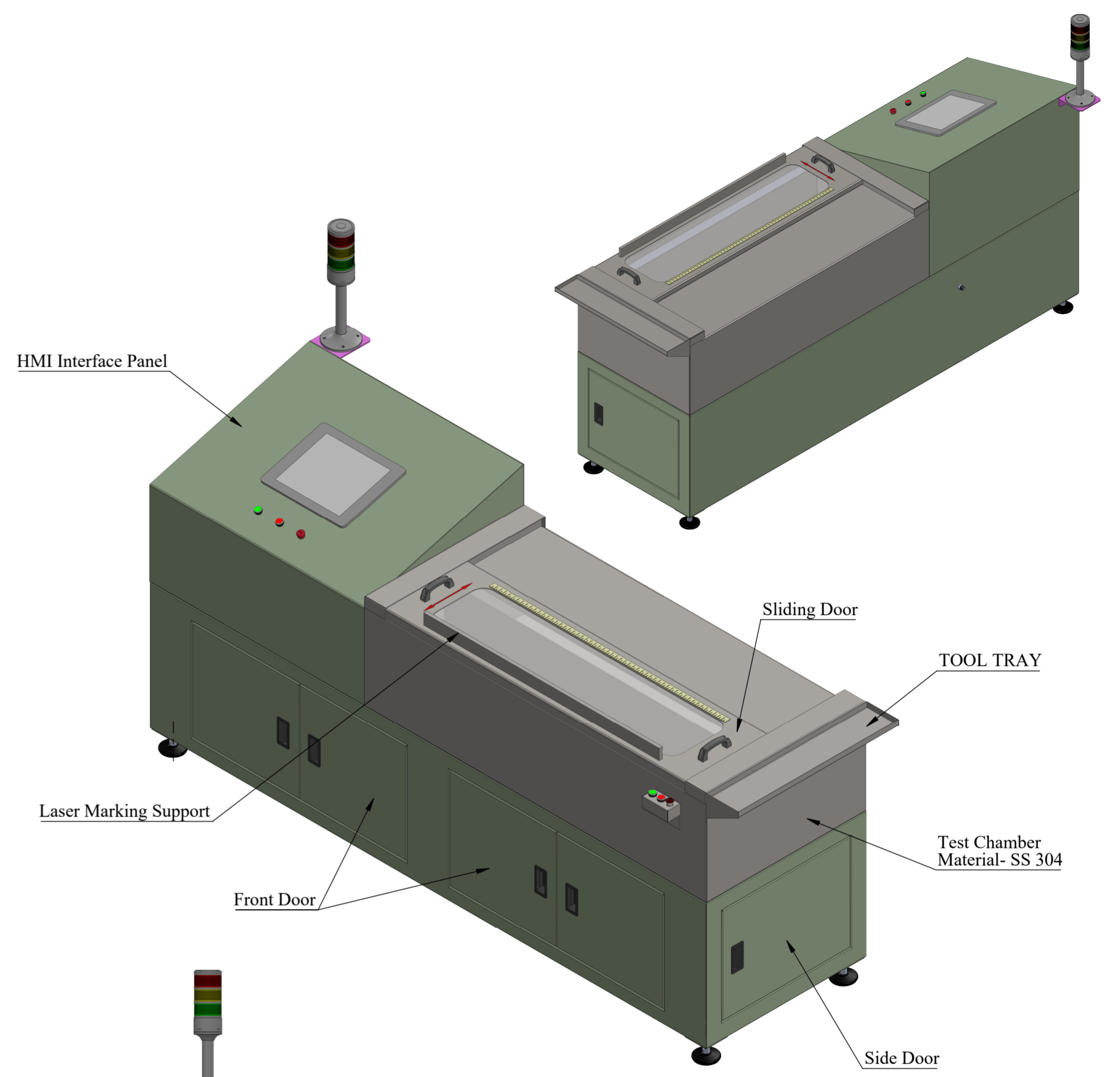

ISOMETRIC VIEW

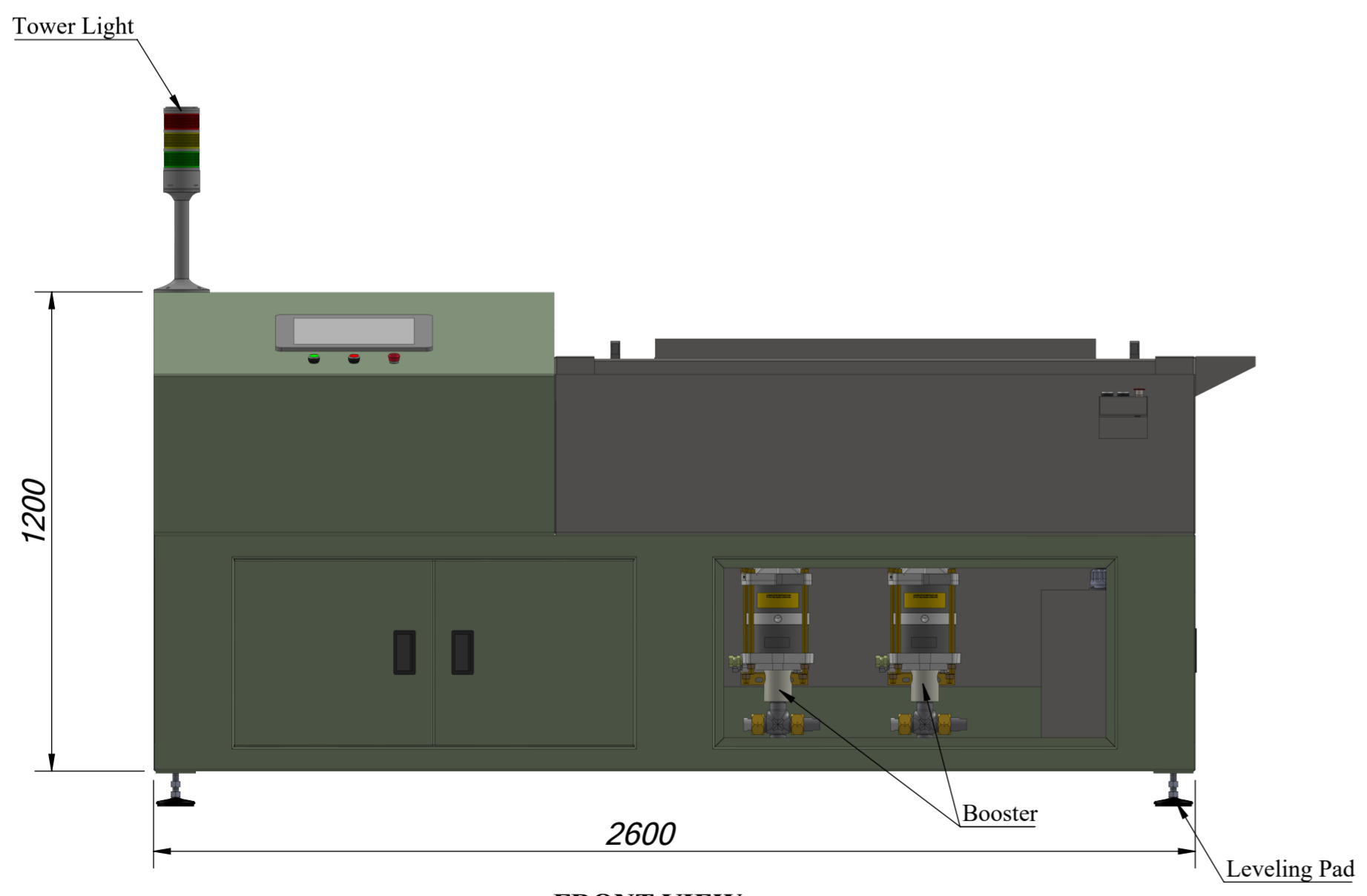

FRONT VIEW

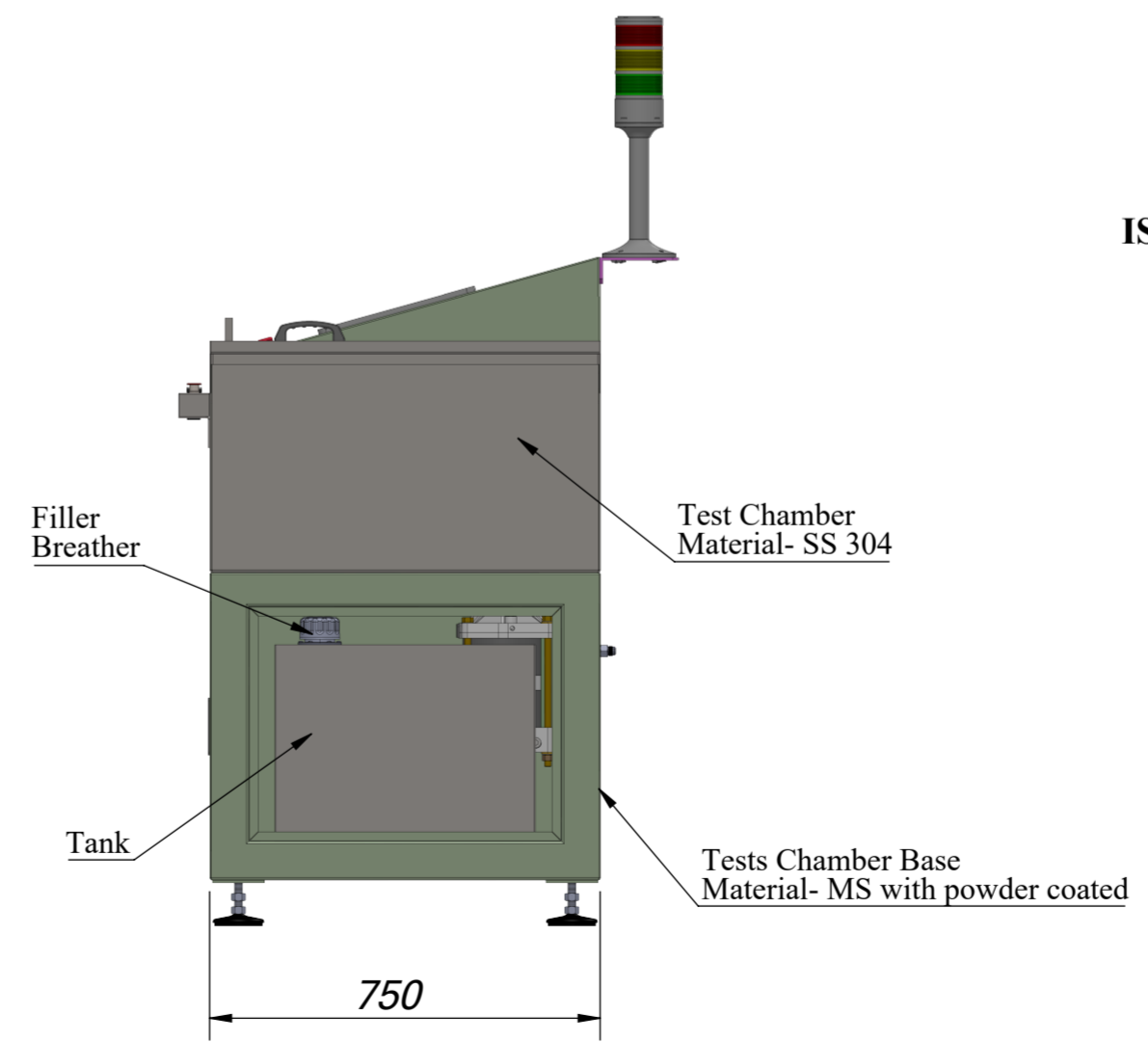

SIDE VIEW

NOTE:-
1. ALL DIMENSIONS ARE IN MM.

PASKALS Fluid Systems		PASKALS FLUID SYSTEM PVT LTD. E-148, SECTOR 63, NOIDA, UP-201301 Tel No.: 0120 4500890 Fax No.: 0120 4500888 E-mail: bd@paskals.com	
TITLE	HYDRAULIC BURST TEST RIG		QA No.
SUB-TITLE	GA DRAWING		Cross Ref Doc No.:
SRS CODE	P3333		Customer Dwg Ref No.
CUSTOMER	--		NOTE :
END USER	--		
TD/PO. No.	--		
PROJECTION	DRWN	M.F	25/06/2024
	CHK.	S.K	25/06/2024
	APPR.	S.P.S	25/06/2024
SIZE	SCALE	SHEET No	OF
A3	NTS	01	01
DATED			REV
NEO DWG No.			
T-DAP-P3333-GADWG-HBTR			01

NOTE:-
THIS IS TENTATIVE DRAWING, SUBJECT TO CHANGE.