

HELIUM DECANTING SYSTEM

A MUST HAVE FOR GAS RECOVERY & RECHARGING PROCESS!



Helium Decanting System is a HIGH PRESSURE facility for **Decanting of the Helium Flight Bottles** which are accessories to emergency floatation system of the Helicopter.

Helium Gas at 400 bar is filled in these bottles of capacity 9 & 18 liters and get utilized or vented during emergency landing of the helicopter on water. These Bottles are returned back in empty/vented condition and semi filled /filled (in case of not use) to the Base and where there is need of Recovery of Helium Gas (Decanting) the tested bottles with Helium Gas at 400 bar.

Due to their legendary quality & reliability under the toughest worldwide conditions combined with excellent price quality ratio the compact line high pressure products from are first choice of Industry Professional.

SYSTEM DETAILS

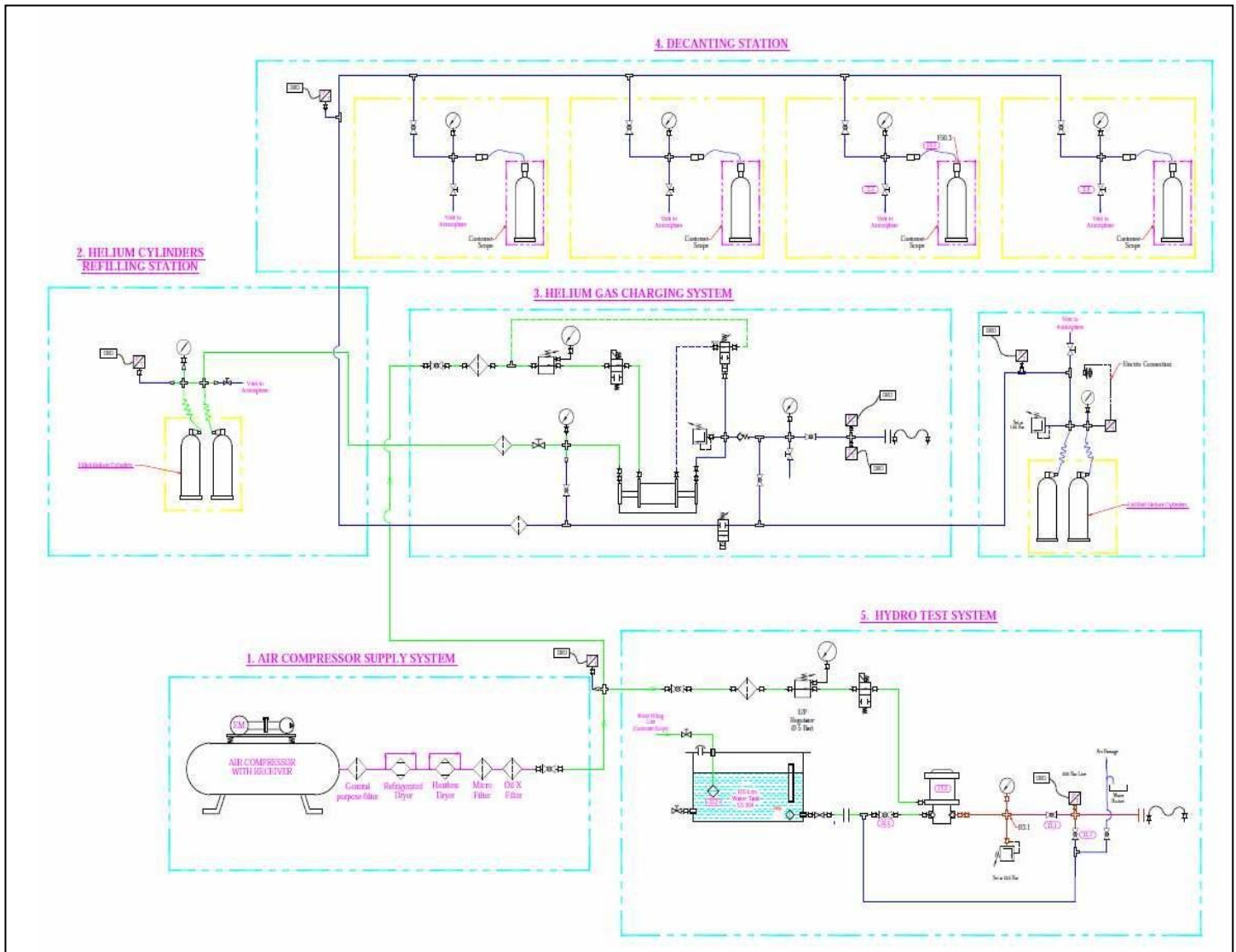

High Pressure HELIUM is recovered and pressurized using Air Driven Gas Booster from Haskel USA (www.haskel.com) up to 400 bar.

SYSTEM SPECIFICATIONS

Sl .No.	Characteristic	Value of Characteristic
1	Air Drive Pressure	7 Bar
2	Air Consumption	40-50 scfm
3	Flight Bottle Specs	WP 289 bar ,WC 18 Liters & WP 239,WC 9 Liters
4	Rejection Pressure after Decanting	15-20 bar
5	Maximum Recovery Pressure	>150 bar ,WC 9,18 Liters
6	Recharging Pressure in the Tested Flight Bottles	WP 289 bar ,WC 18 Liters & WP 239,WC 9 Liters

KEY FEATURES

HELIUM BOTTLES Decanting Station

This system involves evacuation of already filled Helium gas inside the Bottles which is at a maximum pressure of 289 Bar (for 18 liters bottle @ 30fC) and 239 Bar (for 9 liters bottle @ 30fC). This high pressure Helium gas is transferred to empty Storage Cylinders at an equalized low pressure and then Pressurized to a High Pressure in range of 150-200 bar.

This station consists of four sub-stations where we can decant four different Flight Bottles at rated pressure simultaneously in one time. The decanted helium gas is then stored in Storage Gas Cylinders at a high pressure which can be used in Refilling of Tested Helium Flight Bottles.

Each sub-station is equipped with pressure measuring devices (Pressure gauges) to measure the pressure of each Flight Bottles at the time of Decanting. A VENT VALVE is also provided for removing pressurized helium gas from the circuit after decanting is done.



KEY FEATURES**Refilling Station**

Hydraulically tested helium bottles are now put on Refilling Station. In this operation tested helium bottles are filled with helium gas at a pressure of 289 Bar (for 18 liters bottle @ 30fC) and 239 bar (for 9 liters bottle @ 30fC).

Refilling Station consists of a WATER CHAMBER with rigid HOLDING CLAMPS meant for both sizes of Flight Bottles i.e. 9 liters and 18 liters. Before Refilling Operations Flight Bottles are rigidly clamped inside Water Chamber and then this chamber is filled with water to compensate for cylinder heating during High Pressure Gas filling.

Operator can monitor the Refilling Pressure on respective pressure gauge. This allows operator maintain a safe distance from HIGH PRESSURE Flight Bottles during Refilling.

**OTHER FEATURES**

- i. **High Pressure Safety Interlocks** are incorporated in the system to safeguard against sudden rise in pressure.
- ii. All measuring instruments are **calibrated** from certified labs to ensure accurate indication of pressure.
- iii. **Proper Vent** of pressurized Helium gas out of the Testing Workshop is routed to ensure safety of operators against excess helium accumulation in the workshop.
- iv. High pressure containers are shielded with a robust shield metal sheet cover.
- v. The system is also supplied with Quality Assurance certificates i.e. **Leak Test Certificate, Operational Certificate, Relief valve Certificate and Air Pilot Switch Test Certificate**.

*Please Consult Factory for further details.